



INVERTER

Plug-in option

FR-A7ND E kit

INSTRUCTION MANUAL

DeviceNet CONFORMANCE TESTED *communication function*

PRE-OPERATION INSTRUCTIONS

1

INSTALLATION

2

WIRING

3

INVERTER SETTING

4

FUNCTIONS

5

OBJECT MAP DEFINITIONS

6

OBJECT MAP

7

TROUBLESHOOTING

8

Thank you for choosing this Mitsubishi Inverter plug-in option. This instruction manual gives handling information and precautions for use of this equipment. Incorrect handling might cause an unexpected fault. Before using the equipment, please read this manual carefully to use the equipment to its optimum. Please forward this manual to the end user.

This section is specifically about safety matters

Do not attempt to install, operate, maintain or inspect this product until you have read through this instruction manual and appended documents carefully and can use the equipment correctly. Do not use this product until you have a full knowledge of the equipment, safety information and instructions.

In this instruction manual, the safety instruction levels are classified into "WARNING" and "CAUTION".

WARNING

Assumes that incorrect handling may cause hazardous conditions, resulting in death or severe injury.

CAUTION

Assumes that incorrect handling may cause hazardous conditions, resulting in medium or slight injury, or may cause physical damage only.

Note that even the  **CAUTION** level may lead to a serious consequence according to conditions. Please follow the instructions of both levels because they are important to personnel safety.

SAFETY INSTRUCTIONS

1. Electric Shock Prevention

WARNING

- While power is on or when the inverter is running, do not open the front cover. You may get an electric shock.
- Do not run the inverter with the front cover or wiring cover removed. Otherwise, you may access the exposed high-voltage terminals and charging part and get an electric shock.
- If power is off, do not remove the front cover except for wiring or periodic inspection. You may access the charged inverter circuits and get an electric shock.
- Before starting wiring or inspection, check to make sure that the indication of the inverter operation panel is off, wait for at least 10 minutes after the power supply has been switched off, and check that there are no residual voltage using a tester or the like. The capacitor is charged with high voltage for some time after power off and it is dangerous.
- Any person who is involved in the wiring or inspection of this equipment should be fully competent to do the work.
- Always install the plug-in option before wiring. Otherwise, you may get an electric shock or be injured.
- Do not touch the plug-in option with wet hands. Otherwise you may get an electric shock.
- Do not subject the cables to scratches, excessive stress, heavy loads or pinching. Otherwise you may get an electric shock.

2. Injury Prevention

CAUTION

- Apply only the voltage specified in the instruction manual to each terminal. Otherwise, burst, damage, etc. may occur.
- Ensure that the cables are connected to the correct terminals. Otherwise, burst, damage, etc. may occur.
- Always make sure that polarity is correct to prevent damage, etc. Otherwise, burst, damage may occur.
- While power is on or for some time after power-off, do not touch the inverter as it is hot and you may get burnt.

3. Additional Instructions

Also note the following points to prevent an accidental failure, injury, electric shock, etc.

1) Transportation and mounting

CAUTION

- Do not install or operate the plug-in option if it is damaged or has parts missing.
- Do not stand or rest heavy objects on the product.
- Check that the mounting orientation is correct.
- Prevent other conductive bodies such as screws and metal fragments or other flammable substance such as oil from entering the inverter.

2) Trial run

CAUTION

- Before starting operation, confirm and adjust the parameters. A failure to do so may cause some machines to make unexpected motions.

3) Usage

WARNING

- Do not modify the equipment.
- Do not perform parts removal which is not instructed in this manual. Doing so may lead to fault or damage of the inverter.

CAUTION

- When parameter clear or all parameter clear is performed, reset the required parameters before starting operations. Each parameter returns to the initial value.
- For prevention of damage due to static electricity, touch nearby metal before touching this product to eliminate static electricity from your body.

4) Maintenance, inspection and parts replacement

CAUTION

- Do not test the equipment with a megger (measure insulation resistance).

5) Disposal

CAUTION

- Treat as industrial waste.

6) General instruction

All illustrations given in this manual may have been drawn with covers or safety guards removed to provide in-depth description. Before starting operation of the product, always return the covers and guards into original positions as specified and operate the equipment in accordance with the manual.

— CONTENTS —

1	PRE-OPERATION INSTRUCTIONS	1
1.1	Unpacking and Product Confirmation	1
1.1.1	SERIAL number	1
1.1.2	Packing confirmation	2
1.2	Parts	3
1.3	MNS LED (operation status indication)	4
1.4	Specifications	5
2	INSTALLATION	6
2.1	Pre-Installation Instructions	6
2.2	Installation Procedure	6
2.3	Node Address Setting	12
3	WIRING	14
3.1	Connection to Network	14
3.2	Wiring	15
4	INVERTER SETTING	19
4.1	Parameter List	19
4.2	DeviceNet Data	20

4.2.1	DeviceNet address (Pr. 345)	21
4.2.2	DeviceNet baud rate (Pr. 346).....	22
4.3	Operation Mode Setting	24
4.3.1	Operation mode indication.....	24
4.3.2	Operation mode switching and communication startup mode (Pr. 79, Pr. 340)	25
4.4	Operation and Speed Command Source (Pr. 338, Pr. 339, Pr. 550)	28
4.4.1	Communication EEPROM write selection (Pr. 342)	32
4.5	Operation at Communication Error Occurrence	33
4.5.1	Operation selection at communication error occurrence (Pr. 500 to Pr. 502)	33
4.5.2	Alarm and measures	37
4.6	Inverter Reset	38
4.7	Frequency and Speed Conversion Specifications	40
5	FUNCTIONS	41
5.1	Output from the Inverter to the Network.....	41
5.2	Input to the Inverter from the Network.....	41
6	OBJECT MAP DEFINITIONS	42
6.1	Object Model of DeviceNet Communication	42
6.2	Response Level.....	43
6.2.1	Response level of Polling I/O	43
6.2.2	Response level of explicit message	44
6.3	Recommendation for Software Design.....	45

7	OBJECT MAP	46
7.1	Class 0x01 (Identity-Object)	46
7.1.1	Class 0x01 Instance 0	46
7.1.2	Class 0x01 Instance 1	47
7.2	Class 0x03 (DeviceNet Object)	48
7.2.1	Class 0x03 Instance 1	48
7.3	Class 0x04 (Assembly Object)	50
7.3.1	Output Instance 20/Input Instance 70.....	51
7.3.2	Output Instance 21/Input Instance 71.....	53
7.3.3	Output Instance 126/Input Instance 176.....	55
7.4	Class 0x05 (DeviceNet Connection Object)	59
7.4.1	Class 0x05 Instance 1 Attribute (Explicit message connection).....	59
7.4.2	Class 0x05 Instance 2 Attribute (Polling I/O connection)	61
7.4.3	Class 0x05 Instance 4, 5, 6 Attribute (Explicit message connection).....	64
7.4.4	Class 0x05 Instance 1, 2, 4, 5, 6 service.....	65
7.5	Class 0x28 (Motor Data Object)	66
7.5.1	Class 0x28 Instance 1	66
7.6	Class 0x29 (Control Supervisor Object)	67
7.6.1	Class 0x29 Instance 1	67
7.7	Class 0x2A (AC Drive Object)	69
7.7.1	Class 0x2A Instance 1.....	69
7.8	Class 0x66 (Extended Object I)	79
7.8.1	Class 0x66 Instance 1	79
7.9	Class 0x67 (Extended Object II)	84

7.9.1	Class 0x67 Instance 1	84
7.10	Class 0x70 to 0x79 (Extended Object III)	86
7.10.1	Class 0x70 to 0x79 Instance 1, 2	86
7.11	Class 0x80 (Extended Object IV)	87
7.11.1	Class 0x80 Instance 1	87

8 TROUBLESHOOTING **89**

APPENDIX **90**

EDS file	90
Error Code List.....	91

1 PRE-OPERATION INSTRUCTIONS

1.1 Unpacking and Product Confirmation

Take the plug-in option out of the package, check the product name, and confirm that the product is as you ordered and intact.

This product is a plug-in option for the FR-E700 series inverter.

1.1.1 SERIAL number

Check the SERIAL number indicated on the rating plate or package.

For the 200V class of FR-E700, this option can be used with the inverter having the following SERIAL number or later. (For the 400V class of FR-E700, this option can be used with all inverters regardless of SERIAL number.)

Type	SERIAL number
FR-E720-0.1K to 0.75K	J7Y○○○○○○
FR-E720-1.5K to 5.5K	K7Y○○○○○○
FR-E720-7.5K	L7Y○○○○○○
FR-E720-11K, 15K	G7Y○○○○○○

● SERIAL number check

Refer to the inverter manual for the location of the rating plate.

Rating plate example



\square 7 Y ○○○○○○] SERIAL (Serial No.)
Symbol Year Month Control number

The SERIAL consists of 1 version symbol, 2 numeric characters or 1 numeric character and 1 alphabet letter indicating year and month, and 6 numeric characters indicating control number.

Month is indicated as 1 to 9, X (October), Y (November), and Z (December).

1.1.2 Packing confirmation

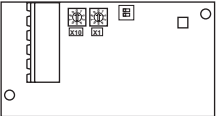
Check the enclosed items.

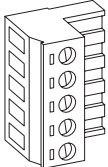
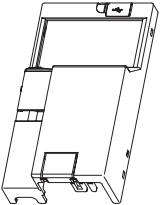
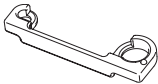
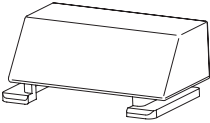
<p>Plug-in option 1</p> 	<p>Mounting screw (M3 × 6mm) 2 (Refer to page 8, 10.)</p> 	<p>Terminal block 1 (Refer to page 8, 10.)</p> 
<p>Front cover for plug-in option 1</p> 	<p>Option protective cover 1*</p> 	<p>Option small cover (Not used) 1</p> 

* Used with the FR-E720-3.7K (FR-E720-175) or less and FR-E740-7.5K (FR-E740-170) or less.

CAUTION

• In place of the inverter front cover, install a provided front cover for plug-in option.

REMARKS

• DeviceNet is a registered trademark of ODVA (Open DeviceNet Vender Association, INC).

1.2 Parts

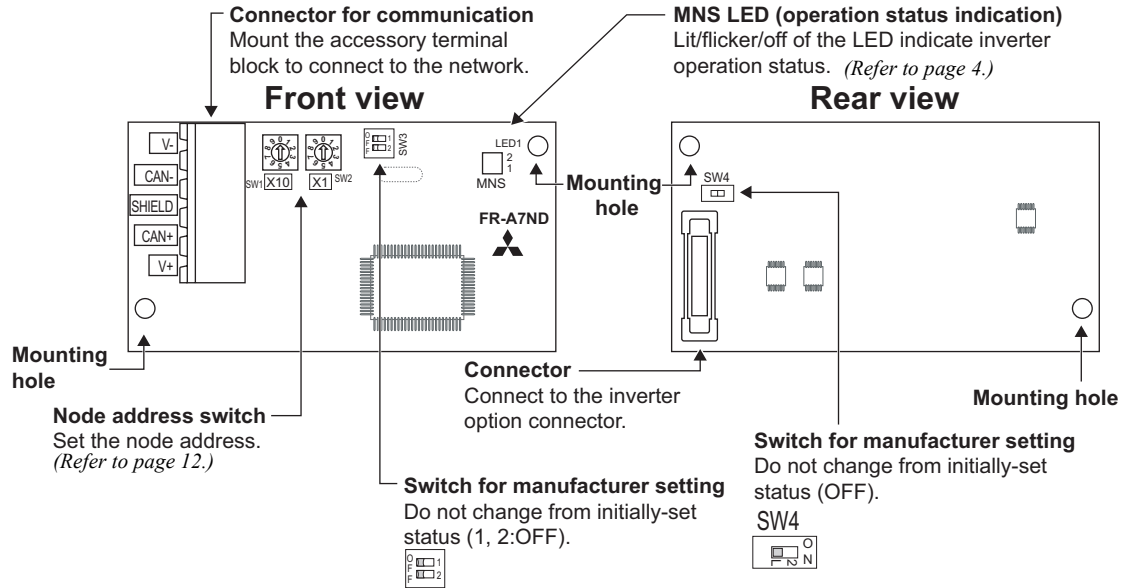

1

1.3 MNS LED (operation status indication)

MNS LED indicates the operating status of the option unit according to the indication status.

Check the position of LED on *page 3*.

LED Indication	Operating Status	Note
Off	Inverter power off Network power off Own node only on the network	<ul style="list-style-type: none"> · Turn inverter power on. Option unit will then complete duplicate station number test. · Check the voltage of the network power. · Add other nodes to the network.
Green (flickering)	Network and inverter power on Connection not yet established by host	The inverter power turns on and duplicate of node address is being checked. However, a host has not yet established a communication link.
Green (lit)	Network and inverter power on Connection established by host	A master device on the network has designated the option unit for communications. LED holds the state also during communication.
Red (flickering)	Connection time-out	Master designated the option unit for communication on the network, but then sent no messages within the time limit * set in the expected packet rate.
Red (lit)	Critical link failure	<p>Check for the followings.</p> <ul style="list-style-type: none"> · Duplicate node address on the network · Cable from option unit to network not connected or severed. · Network damaged <p>Take the appropriate corrective action, then reset the inverter to recover from the fault.</p>

* Time limit = 4 × EPR (EPR = Expected Pack Rate Class 0x05 Instance 1 Attribute 9 (*refer to page 60*))

1.4 Specifications



Item		Specifications
Power supply	Control power supply	Supplied from the inverter
	External power input	Input voltage: 11 to 28V Consumption current: 90mA maximum
Standard		Conforms to ODVA DeviceNet Specification Release 2.0 (support UCMM)
Network topology		DeviceNet (linear bus with drop lines)
Communication cable		DeviceNet standard thick or thin cable (For a drop cable, use a thin cable.)
Maximum cable length		500m (125kbps) 250m (250kbps) 100m (500kbps)
Communication speed		125kbps, 250kbps, 500kbps
Number of inverters connected		64 (including master) The number of inverters connectable is $64 - 1 = 63$ when a minimum of one node as a master is connected.
Response time		Refer to <i>page 43</i> .

2 INSTALLATION

2.1 Pre-Installation Instructions

Make sure that the input power of the inverter is off.

CAUTION

-  With input power on, do not install or remove the plug-in option. Otherwise, the inverter and plug-in option may be damaged.
-  For prevention of damage due to static electricity, touch nearby metal before touching this product to eliminate static electricity from your body.

2.2 Installation Procedure

The FR-E700 series has one connection connector for the plug-in option.

CAUTION

- Always perform wiring to the main circuit terminals and control circuit terminals before installing the option. Wiring cannot be performed after installing the option.
- When the inverter can not recognize that the option unit is mounted due to improper installation, etc., "E. I" (option alarm) is displayed.
- Take care not to drop a mounting screw during mounting and removal.
- Pull out the option straight to remove. Otherwise, the connector may be damaged.

- For FR-E720-3.7K (FR-E720-175) or less and FR-E740-7.5K (FR-E740-170) or less
- (1) Remove the front cover from the inverter. (For removing the front cover, refer to the FR-E700 instruction manual.)
 - (2) Remove the PU cover from the front cover. Open the PU cover with a driver, etc. and remove it in the direction of arrow as shown below.

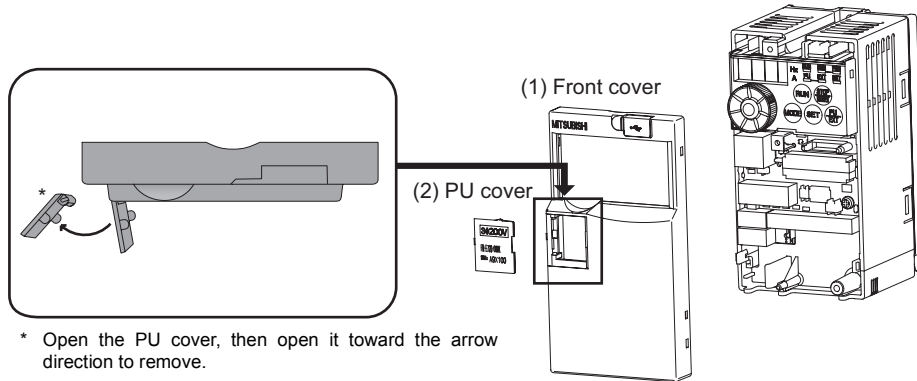

REMARKS

- Because the capacity plate and serial (only voltage is written for FR-E740-5.5K (FR-E740-120) or more) are stated on the PU cover, replace a PU cover of a plug-in option front cover with the removed PU cover from the inverter.

7 INSTALLATION

- (3) Install the option protective cover.
- (4) Securely fit the connector of the plug-in option to the inverter connector along the guides.
- (5) Securely fix the both top and bottom of the plug-in option to the inverter with the accessory mounting screws. (tightening torque $0.45\text{N}\cdot\text{m}$ to $0.55\text{N}\cdot\text{m}$) If the screw holes do not line-up, the connector may not have been plugged snugly. Check for loose plugging.
- (6) Remove the PU cover provided on the front cover for plug-in option and install the other PU cover, which was removed in (2).
- (7) Mount the already wired terminal block to the plug-in option. (Refer to *the chapter 3* for wiring.)
- (8) Install the front cover for plug-in option to the inverter.

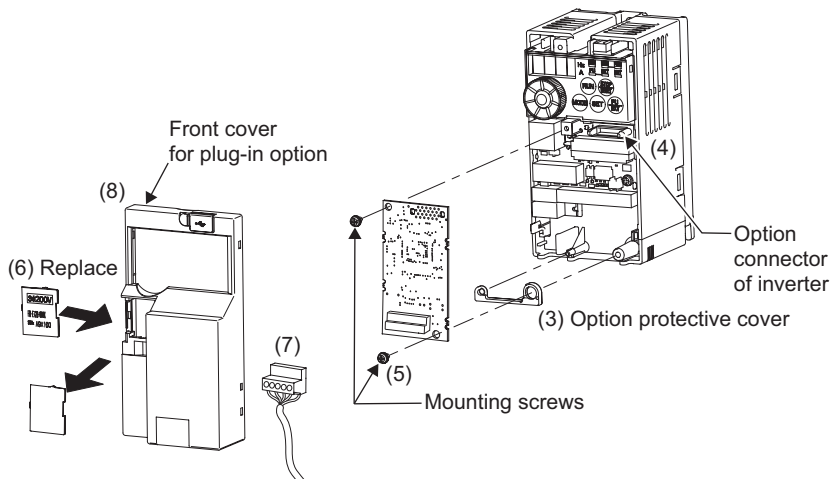

REMARKS

- When the option protective cover is not installed, the protective structure (JEM1030) changes to open type (IP00).

- For FR-E720-5.5K (FR-E720-240) or more and FR-E740-11K (FR-E740-230) or more
- (1) Remove the front cover 1 and 2 from the inverter. (For removing the front cover, refer to the FR-E700 instruction manual.)
 - (2) Remove the PU cover from the front cover 2. For removing the PU cover, refer to *page 7*.

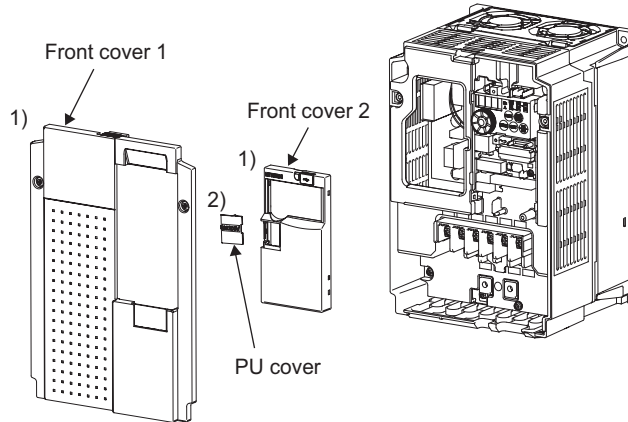

REMARKS

- Because the voltage is stated on the PU cover, replace a PU cover of a plug-in option front cover with the removed PU cover from the inverter.

- (3) Install the front cover 1 to the inverter.
- (4) Securely fit the connector of the plug-in option to the inverter connector along the guides.
- (5) Securely fix the both top and bottom of the plug-in option to the inverter with the accessory mounting screws. (tightening torque 0.45N•m to 0.55N•m) If the screw holes do not line-up, the connector may not have been plugged snugly. Check for loose plugging.
- (6) Remove the PU cover provided on the front cover for plug-in option and install the other PU cover, which was removed in (2).
- (7) Mount the already wired terminal block to the plug-in option. (Refer to *the chapter 3* for wiring.)
- (8) Install the front cover for plug-in option to the inverter.

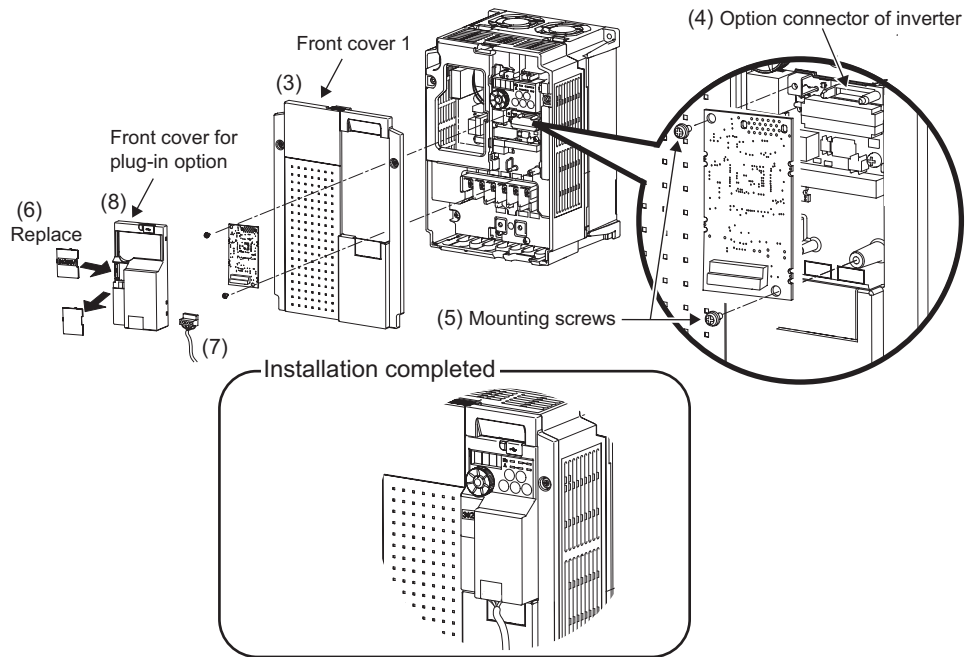

2.3 Node Address Setting

(1) Setting with node address switch

Set the node address between "0 to 63" using node address switches on the FR-A7ND (refer to page 3). The setting is reflected when power turns on next or the inverter is reset.

Set Pr. 345 or Class 0x03 Instance 1 Attribute 1 to "63 (initial value)".

Set the arrow (↑) of the corresponding switches to the number to set a desired address.

● Setting example

Node address 1:

Set the "↑" of X10(SW1) to "0" and the "↑" of X1(SW2) to "1".

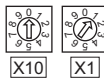

Node address 26:

Set the "↑" of X10(SW1) to "2" and the "↑" of X1(SW2) to "6".

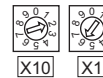

CAUTION

- Set the node address switch to the switch number position correctly. If the switch is set between numbers, normal data communication can not be made.

Good example



Bad example



- When the node address switch is set to values other than "0 to 63", they are regarded as "63".
- You cannot set the same node address to other devices on the network. (Doing so disables proper communication.)
- Set the inverter node address before switching on the inverter and do not change the setting while power is on. Otherwise you may get an electric shock.

(2) Set with parameter (Pr. 345)

Use parameter (Pr. 345) of the inverter to set. Setting node address with parameter makes the node address setting invalid. The setting is reflected at the next power-on or inverter reset. (Refer to page 21)

(3) Setting with master

Use Class 0x03 Instance 1 Attribute 1 to set from the master. The setting change is reflected to Pr. 345. Setting node address from the master makes the node address switch setting invalid. (Refer to page 48)
All connections are released and a set value is immediately reflected.

3 WIRING

3.1 Connection to Network

- (1) Be sure to check the following before connecting the inverter to the network.
 - Check that the FR-A7ND is snugly inserted into the inverter. (Refer to page 6.)
 - Check that the correct node address is set. (Refer to page 12.)
 - Check that a drop cable is firmly connected to the FR-A7ND. (Refer to page 15.)
- (2) Make sure that the terminating resistor is installed at each end (between CAN+ and CAN-) of the trunk cable. These resistors must meet the following requirements.

Requirements of Terminating Resistors		
R (resistance value) = 121Ω	1% metal film	0.25 W

- (3) Connect drop cables to the trunk cable.

- If the trunk connector is a DeviceNet sanctioned pluggable or sealed connector, the connection to the active network can be made at any time whether the inverter is on or off. The option unit automatically detects when the connection is completed.
- If connecting to the network with free wires, power to the network and inverter should be shut off as a safety precaution in case two or more signal wires are accidentally shorted together.

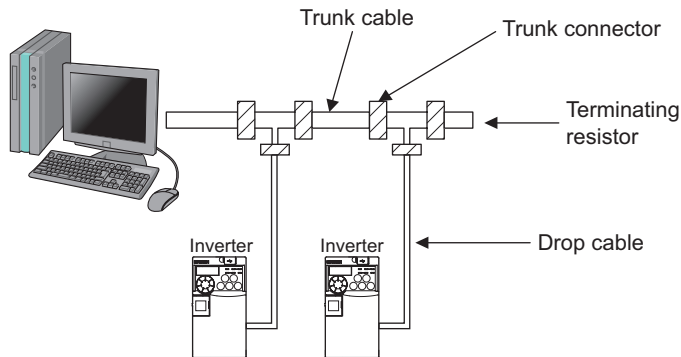

3.2 Wiring

- (1) Strip the insulation back about 40mm on the free wire end of the drop cable to expose the four colored signal wires and the silver shield wire.
- (2) Strip the insulation back of each signal cable to use. If the length of the sheath peeled is too long, a short circuit may occur among neighboring wires. If the length is too short, wires might come off.

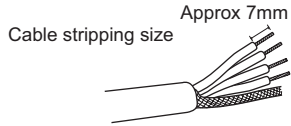

**Wire the stripped cable after twisting it to prevent it from becoming loose.
(Do not solder it.)
Use a bar type terminal as required.**

REMARKS

- Information on bar terminals...recommended product (as of September, 2006)

Terminal Screw Size	Cable Size (mm ²)	Bar Terminal Model		Maker
		With insulation sleeve	Without insulation sleeve	
M3	0.3 to 0.5	AI 0,5-6WH	A 0,5-6	Phoenix Contact Co.,Ltd.
	0.5 to 0.75	AI 0,75-6GY	A 0,75-6	

Bar terminal crimping tool: CRIMPFOX ZA3 (Phoenix Contact Co., Ltd.)

When using the bar terminal (without insulation sleeve), use care so that the twisted wires do not come out.

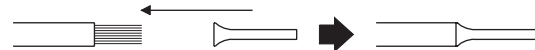

- (3) Loosen the terminal screw and insert the cable into the terminal according to the terminal arrangement. Tighten each cable with fixing screws to the recommended tightening torque.

Screw Size	Tightening Torque	Cable Size	Screwdriver
M3	0.5N•m to 0.6N•m	0.3mm ² to 0.75mm ²	Small ⊖ flat-blade screwdriver (Tip thickness: 0.4mm/tip width: 2.5mm)

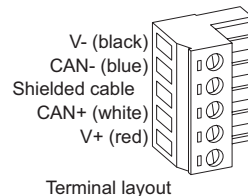

CAUTION

- **Undertightening can cause cable disconnection or malfunction. Overtightening can cause a short circuit or malfunction due to damage to the screw or unit.**
- (4) Connect the terminal block to the connector for communication of the communication option mounted on the inverter.

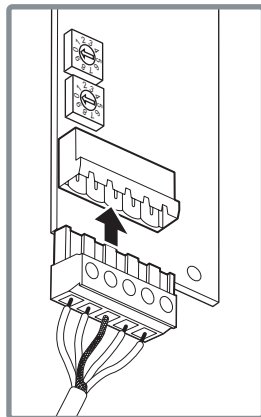

- (5) When wiring the FR-E700 series, if a hook of the front cover of the plug-in option impedes wiring, cut off the hook and perform wiring.

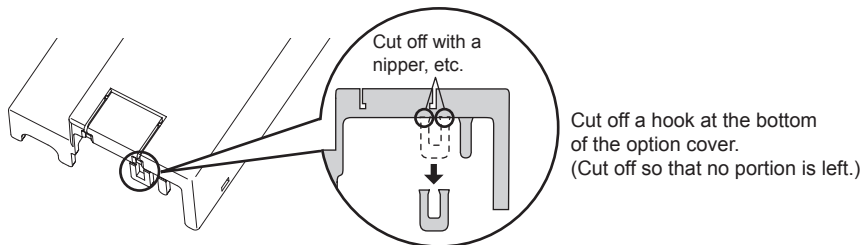

**REMARKS**

- When the option protective cover is not fitted or wire is not passed through even if the hook of the front cover of the plug-in option has been cut off, the protective structure (JEM1030) changes to open type (IP00).

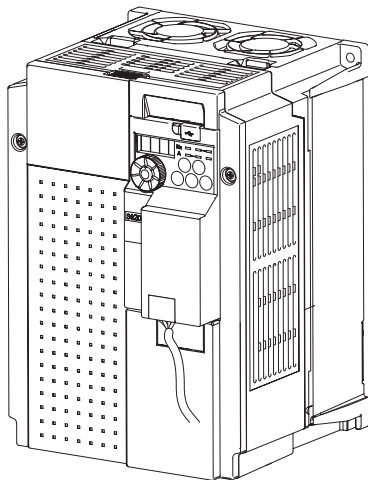
- (6) For wiring of FR-E720-5.5K (FR-E720-240) or more and FR-E740-11K (FR-E740-230) or more, pass a cable on the inverter front cover as shown below. If a drop cable is passed through inside the inverter front cover, the bending radius of the cable becomes small, stressing the cable.



CAUTION

-  **When wiring, take care not to subject the cable to stress.**
-  **After wiring, wire offcuts must not be left in the inverter. They may cause a fault, failure or malfunction.**

4 INVERTER SETTING

4.1 Parameter List

The following parameters are used for the communication option (FR-A7ND)
Set the values according to need.

Parameter Number	Name	Setting Range	Minimum Setting Increments	Initial Value	Refer to Page
79	Operation mode selection	0 to 4, 6, 7	1	0	25
338	Communication operation command source	0, 1	1	0	29
339	Communication speed command source	0, 1, 2	1	0	29
340	Communication startup mode selection	0, 1, 10	1	0	25
342	Communication EEPROM write selection	0, 1	1	0	32
345 *1	DeviceNet address	0 to 4095	1	63	21
346 *1	DeviceNet baud rate	0 to 4095	1	132	22
349 *1	Communication reset selection	0, 1	1	0	39
500 *1	Communication error execution waiting time	0 to 999.8s	0.1s	0	33
501 *1	Communication error occurrence count display	0	1	0	34
502 *2	Stop mode selection at communication error	0, 1, 2, 3	1	0	35
550 *2	NET mode operation command source selection	0, 2, 9999	1	9999	28

*1 Parameters which can be displayed when the plug-in option (FR-A7ND) is mounted.

*2 The setting is reflected after inverter reset or at the next power-on.

4.2 DeviceNet Data

DeviceNet communication startup data can be set with the inverter parameter without using a DeviceNet configuration tool.

For the setting method with a EDS file (*refer to page 90*) DeviceNet configuration tool, refer to the configuration tool manual.

4.2.1 DeviceNet address (Pr. 345)

Parameter Number	Name	Setting Range	Minimum Setting Increments	Initial Value
345	DeviceNet address	0 to 4095	1	63

The definition of *Pr. 345* is as follows.

Bit15	Bit14	Bit13	Bit12	Bit11	Bit10	Bit9	Bit8	Bit7	Bit6	Bit5	Bit4	Bit3	Bit2	Bit1	Bit0	
Address Key (AKey)					Not Available						Device Node Address (Addr)					

└─ Communication continuation selection(ResCom)

Bit	Item	Initial Value	Setting Range	Definition	
0 to 5	Device Node Address (Addr)	63	0 to 63	Node Address (MAC ID) of device is set between 0 to 63. Set "63" (initial value) to set node address with node address switch.	Node address can be set with DeviceNet Object Class 0x03, Instance1, Attribute1. (Refer to page 48)
11	Selection of continuous communication at inverter reset (ResCom)	0	0	Reset the option unit in synchronization with the inverter. When connection is timed out, communication may not resume according to the master action. In this case, release connection and reestablish to make communication enabled.	
			1	The option unit will not be reset even if the inverter is reset and communication continues. After inverter reset, preset a value other than "0" in <i>Pr. 340</i> so that the inverter starts in network operation mode.	
12 to 15	Address Key (AKey)	0	0	Set "0" always. When a value other than "0" is set, the inverter operates as when "63" (initial value) is set in <i>Pr. 345</i> .	

4.2.2 DeviceNet baud rate (Pr. 346)

Parameter Number	Name	Setting Range	Minimum Setting Increments	Initial Value
346	DeviceNet baud rate	0 to 4095	1	132

Set baud rate etc. to start DeviceNet communication.

Bit15	Bit14	Bit13	Bit12	Bit11	Bit10	Bit9	Bit8	Bit7	Bit6	Bit5	Bit4	Bit3	Bit2	Bit1	Bit0
Baud Rate Key				Input Assembly (IA)				Output Assembly (OA)				Baud Rate (BR)			

Bit	Item	Initial Value	Setting Range	Definition	
0, 1	Baud Rate (BR)	0	0, 3	125kbps	This value can be set with DeviceNet Object Class 0x03 Instance 1 Attribute 2. (Refer to page 48)
			1	250kbps	
			2	500kbps	
2 to 6	Output Assembly (OA)	1	0	Output Instance 20 (0x14)	<ul style="list-style-type: none"> Set the same value for input assembly and output assembly. The value can be set with Control Supervisor Class 0x29 Instance 1 Attribute 140, 141. (Refer to page 68)
			1	Output Instance 21 (0x15)	
			6	Output Instance 126 (0x7E)	
			Other than the above	Output Instance 21 (0x15)	
7 to 11	Input Assembly (IA)	1	0	Input Instance 70 (0x46)	
			1	Input Instance 71 (0x47)	
			6	Input Instance 176 (0xB0)	
			Other than the above	Input Instance 71 (0x47)	
12 to 15	Baud Rate Key	0	0	Set "0" always. When a value other than "0" is set, the inverter operates as when "132" (initial value) is set in Pr. 346.	

REMARKS

- The *Pr.346* setting differs according to combinations of baud rate and I/O instance.
Refer to the table below to set *Pr.346*.

Output Instance/ Input Instance		20 / 70	21 / 71	126 / 176
		Baud Rate		
	125kbps	0	132 (Initial value)	792
	250kbps	1	133	793
	500kbps	2	134	794

4.3 Operation Mode Setting

The inverter mounted with a communication option has three operation modes.

- (1) PU operation [PU]..... Controls the inverter from the key of the operation panel on the inverter or parameter unit (FR-PU07/FR-PA07).
- (2) External operation [EXT] ... Controls the inverter by switching on/off external signals connected to the control circuit terminals of the inverter.
(The inverter is factory-set to this mode.)
- (3) Network operation [NET] ... Controls the inverter with instructions from the network via the communication option.
(The operation signal and running frequency can be entered from the control circuit terminals depending on the *Pr. 338 Communication operation command source* and *Pr. 339 Communication speed command source* setting.
Refer to page 29.)

4.3.1 Operation mode indication

Operation panel

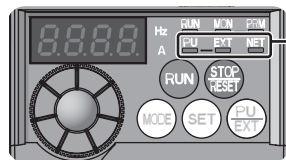

Operation mode indication
(The inverter operates according to the LED lit mode.)
PU: PU operation mode
EXT: External operation mode
NET: Network operation mode

4.3.2 Operation mode switching and communication startup mode (Pr. 79, Pr. 340)

(1) Operation mode switching conditions

Before switching the operation mode, check that:

- 1) The inverter is at a stop;
- 2) Both the STF and STR signals are off; and
- 3) The *Pr. 79 Operation mode selection* setting is correct.

(Set using the operation panel of the inverter or parameter unit (FR-PU07/FR-PA07).)

Refer to *the inverter manual* for details of *Pr. 79*.

(2) Operation mode selection at power on and at restoration from instantaneous power failure

The operation mode at power on and at restoration from instantaneous power failure can be selected.

Set a value other than "0" in *Pr. 340* to select the network operation mode.

After started in network operation mode, parameter write from the network is enabled.

REMARKS

- Change of the *Pr. 340* setting is made valid when powering on or resetting the inverter.
- *Pr. 340* can be changed with the operation panel independently of the operation mode.

Pr. 340 Setting	Pr. 79 Setting	Operation Mode at Power on or Power Restoration	Operation Mode Switchover
0 (initial value)	0 (initial value)	External operation mode	Switching among the external, PU, and NET operation mode is enabled *1
	1	PU operation mode	PU operation mode fixed
	2	External operation mode	Switching between the external and Net operation mode is enabled Switching to the PU operation mode is disallowed
	3, 4	External/PU combined operation mode	Operation mode switching is disallowed
	6	External operation mode	Switching among the external, PU, and NET operation mode is enabled while running.
	7	X12 (MRS) signal ON external operation mode	Switching among the external, PU, and NET operation mode is enabled *1
X12 (MRS) signal OFF ... external operation mode		External operation mode fixed (Forcibly switched to external operation mode.)	
1	0	NET operation mode	Same as when Pr. 340 = "0"
	1	PU operation mode	
	2	NET operation mode	
	3, 4	External/PU combined operation mode	
	6	NET operation mode	
	7	X12 (MRS) signal ON NET operation mode	
X12 (MRS) signal OFF ... external operation mode			
10	0	NET operation mode	Switching between the PU and NET operation mode is enabled *2
	1	PU operation mode	Same as when Pr. 340 = "0"
	2	NET operation mode	NET operation mode fixed
	3, 4	External/PU combined operation mode	Same as when Pr. 340 = "0"
	6	NET operation mode	Switching between the PU and NET operation mode is enabled while running *2
	7	External operation mode	Same as when Pr. 340 = "0"

*1 Operation mode can not be directly changed between the PU operation mode and network operation mode.

*2 Operation mode can be changed between the PU operation mode and network operation mode with  of the operation panel and X65 signal.

(3) Operation mode switching method

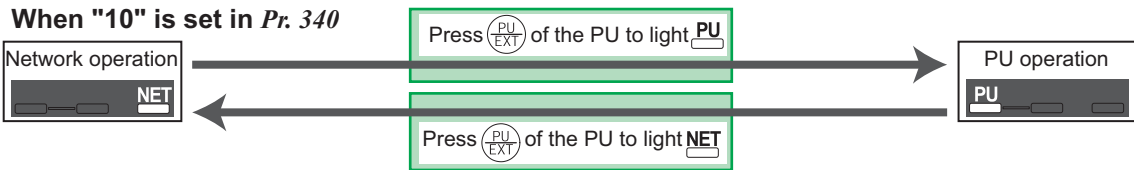
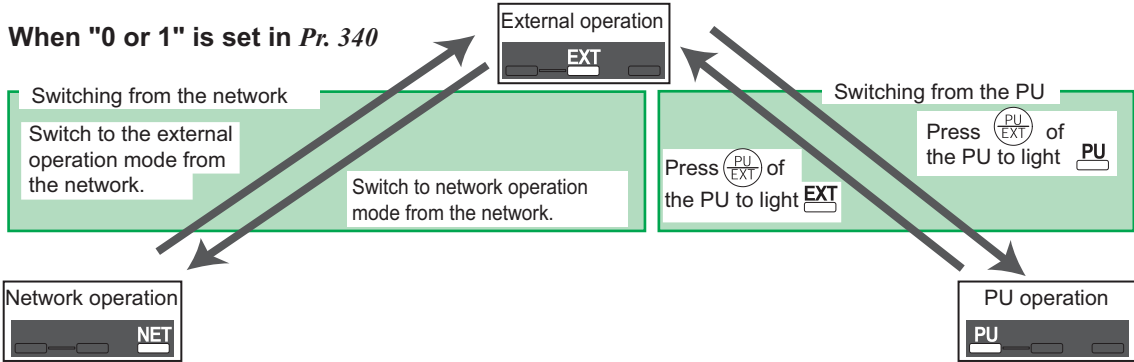

For the switching method from the external terminal, refer to *the inverter manual*.
Refer to *page 72* for a switching method from the network.

CAUTION

- When starting the inverter in network operation mode at powering on or an inverter reset, set a value other than 0 in Pr. 340. (Refer to page 25)
- When setting a value other than 0 in Pr. 340, make sure that the initial settings of the inverter are correct.

4.4 Operation and Speed Command Source (Pr. 338, Pr. 339, Pr. 550)

(1) Select control source for the network operation mode (Pr. 550)

A control location for the network operation mode can be selected from either the RS-485 communication with the PU connector or communication option.

When using a communication option, set "0 or 9999 (initial value)" in Pr. 550.

Parameter Number	Name	Initial Value	Setting Range	Description
550	NET mode operation command source selection	9999	0	Selects the communication option as NET operation mode command source.
			2	Selects the PU connector as the NET operation mode command source.
			9999	Automatic communication option recognition Normally, PU connector is the command source. When a communication option is mounted, the communication option is the command source.

Refer to the inverter manual for details.

(2) Selection of control source for the network operation mode (Pr. 338, Pr. 339)

- As control sources, there are the operation command source that controls the signals related to the inverter start command and function selection and the speed command source that controls the signals related to frequency setting.
- In network operation mode, the commands from the external terminals and communication (PU connector or communication option) are as listed below.

Operation Location Selection		Pr. 338 Communication operation command source		0: NET			1: External			Remarks	
				0: NET	1: External	2: External	0: NET	1: External	2: External		
Fixed function (terminal-equivalent function)		Running frequency from communication		NET	—	NET	NET	—	NET		
		Terminal 2		—	External	—	—	External	—		
		Terminal 4		—	External		—	External			
Selective function	Pr. 178 to Pr. 184 setting	0	RL	Low speed operation command/remote setting clear/stop-on contact selection 0	NET	External		NET	External		Pr. 59 = "0" (multi-speed) Pr. 59 = "1, 2" (remote) Pr. 270 = "1" (stop-on-contact)
		1	RM	Middle speed operation command/remote setting function	NET	External		NET	External		
		2	RH	High speed operation command/remote setting function	NET	External		NET	External		
		3	RT	Second function selection/stop-on contact selection 1	NET			External			Pr. 270 = "1" (stop-on-contact)
		4	AU	Current input selection	—	Combined		—	Combined		
		5	JOG	Jog operation selection	—			External			

7 INVERTER SETTING

Operation Location Selection	Pr. 338 Communication operation command source		0: NET			1: External			Remarks		
	Pr. 339 Communication speed command source		0: NET	1: External	2: External	0: NET	1: External	2: External			
Selective function Pr. 178 to Pr. 184 setting	7	OH	External thermal relay input		External						
	8	REX	Fifteen speed selection	NET	External		NET	External		Pr. 59 = "0" (multi-speed)	
	10	X10	Inverter operation enable signal		External						
	12	X12	PU operation external interlock		External						
	14	X14	PID control valid terminal		NET	External		NET	External		
	15	BRI	Brake opening completion signal		NET			External			
	16	X16	PU-external operation switchover		External						
	18	X18	V/F switching		NET			External			
	24	MRS	Output stop		Combined			External			Pr. 79 ≠ "7"
			PU operation interlock		External					Pr. 79 = "7" When the X12 signal is not assigned	
25	STOP	Start self-holding selection		—			External				
60	STF	Forward rotation command		NET			External				

Operation Location Selection		Pr. 338 Communication operation command source		0: NET			1: External			Remarks	
				0: NET	1: External	2: External	0: NET	1: External	2: External		
Selective function	Pr. 178 to Pr. 184 setting	61	STR	Reverse rotation command	NET			External			
		62	RES	Reset				External			
		65	X65	PU/NET operation switchover				External			
		66	X66	NET-external operation switching				External			
		67	X67	Command source switchover				External			

[Explanation of table]

External : Command is valid only from control terminal.

NET : Command only from communication is valid

Combined : Command from both control terminal and communication is valid.

— : Command from either of control terminal and communication is invalid.

REMARKS

- The command source of communication is as set in Pr. 550 and Pr. 551.
- The Pr. 338 and Pr. 339 settings can be changed while the inverter is running when Pr. 77 = "2". Note that the setting change is reflected after the inverter has stopped. Until the inverter has stopped, communication operation command source and communication speed command source before the setting change are valid.

4.4.1 Communication EEPROM write selection (Pr. 342)

When parameter write is performed from the communication option, write to RAM is enabled. Set when frequent parameter changes are necessary.

Parameter Number	Name	Initial Value	Setting Range	Description
342	Communication EEPROM write selection	0	0	Parameter values written by communication are written to the EEPROM and RAM.
			1	Parameter values written by communication are written to the RAM.

- When changing the parameter values frequently, set "1" in *Pr. 342* to write them to the RAM. Performing frequent parameter write with "0 (initial value)" (EEPROM write) set will shorten the life of the EEPROM.

REMARKS

- When "1" (write to RAM only) is set in *Pr. 342*, powering off the inverter will erase the changed parameter values. Therefore, the parameter values available when power is switched on again are the values stored in EEPROM previously.

4.5 Operation at Communication Error Occurrence

4.5.1 Operation selection at communication error occurrence (Pr. 500 to Pr. 502)

You can select operations at communication error occurrences by setting *Pr. 500 to Pr. 502* under network operation.

(1) The set time from when a communication line error occurrence until communication error output

You can set the waiting time from when a communication line error occurs until it is recognized as a communication error.

Parameter Number	Name	Setting Range	Minimum Setting Increments	Initial Value
500	Communication error execution waiting time	0 to 999.8s	0.1s	0

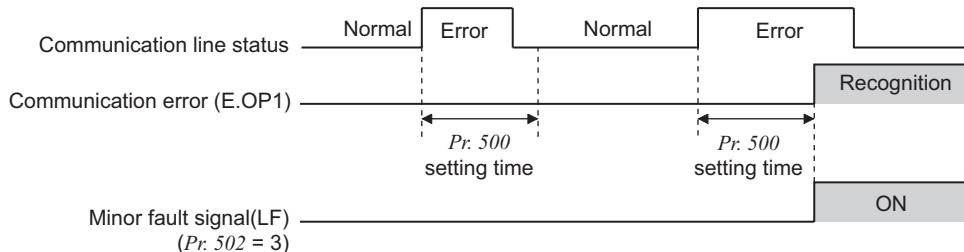

If the communication line error still persists after the time set in *Pr. 500* has elapsed, it is recognized as a communication error.

When the error is restored to normal communication within the set time, it is not regarded as a communication error and operation continues.

(2) Display and erasure of communication error occurrence count

The cumulative number of communication error occurrences can be indicated.

Write "0" to erase this cumulative count.

Parameter Number	Name	Setting Range	Minimum Setting Increments	Initial Value
501	Communication error occurrence count display	0	1	0

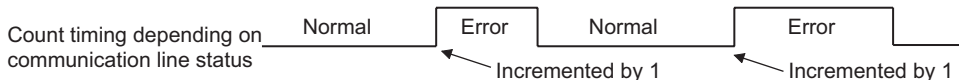

At the point of communication line error occurrence, *Pr. 501 Communication error occurrence count display* is incremented by 1.

CAUTION

- The communication error count occurrence is stored into RAM temporarily. Since this data is stored in EEPROM at one-hour intervals, performing power-on reset or inverter may cause the *Pr. 501* data to be the value stored in EEPROM the last time depending on the reset timing.

(3) Inverter operation selection at communication error occurrence

You can select the inverter operation if a communication line error or an error of the option unit itself occurs.

Parameter Number	Name	Setting Range	Minimum Setting Increments	Initial Value
502	Stop mode selection at communication error	0, 1, 2, 3	1	0

About setting

● Operation at error occurrence

Alarm Definition	Pr. 502 Setting	Operation	Indication	Alarm Output
Communication line	0	Continued *	Normal indication *	Not provided *
	1			
	2			
	3			
Communication option itself	0, 3	Coast to stop	E. 1 lit	Provided
	1, 2	Decelerated to stop	E. 1 lit after stop	Provided after stop

* When the error returns to normal communication within the time set in Pr. 500, it is not regarded as a communication line error (E.OP1).

● Operation at error recognition after elapse of Pr. 500 time

Alarm Definition	Pr. 502 Setting	Operation	Indication	Alarm Output
Communication line	0	Coast to stop	E.OP1 lit	Provided
	1	Decelerated to stop	E.OP1 lit after stop	Provided after stop
	2			Not provided
	3	Continued	Normal indication	
Communication option itself	0, 3	Coast to stop	E. 1 lit	Provided
	1, 2	Decelerated to stop	E. 1 lit after stop	Provided after stop

● Operation at error removal

Alarm Definition	Pr. 502 Setting	Operation	Indication	Alarm Output
Communication line	0	Kept stopped	E.OP1 kept lit	Kept provided
	1			
	2	Restart	Normal indication	Not provided
	3	Continued		
Communication option itself	0, 3	Kept stopped	E. 1 kept lit	Kept provided
	1, 2			

CAUTION

- A communication line error [E.OP1 (alarm data: HA1)] is an error that occurs on the communication line, and an error of the communication option unit itself [E. 1 (alarm data: HF1)] is a communication circuit error in the option.
- The alarm output indicates alarm output signal (ALM signal) or alarm bit output.
- When the setting was made to provide an alarm output, the error definition is stored into the alarm history. (The error definition is written to the alarm history when an alarm output is provided.)
When no alarm output is provided, the error definition overwrites the alarm indication of the alarm history temporarily, but is not stored.
After the error is removed, the alarm indication is reset and returns to the ordinary monitor, and the alarm history returns to the preceding alarm indication.
- When the Pr. 502 setting is "1" or "2", the deceleration time is the ordinary deceleration time setting (e.g. Pr. 8, Pr. 44, Pr. 45).
- The acceleration time at a restart is the ordinary acceleration time setting (e.g. Pr. 7, Pr. 44).
- When the Pr. 502 setting is "2", the operation/speed command at a restart is the one given before the error occurrence.
- When a communication line error occurs at the Pr. 502 setting of "2", removing the error during deceleration causes acceleration to restart at that point. (Acceleration is not restarted if the error is that of the option unit itself.)

4.5.2 Alarm and measures

(1) The inverter operates as follows at alarm occurrences.

Alarm Location	Status		Operation Mode		
			Network Operation	External Operation	PU Operation
Inverter	Inverter operation		Inverter trip	Inverter trip	Inverter trip
	Data communication		Continued	Continued	Continued
Communication line	Inverter operation		Inverter trip *	Continued	Continued
	Data communication		Stop	Stop	Stop
Communication option	Communication option connection error	Inverter operation	Inverter trip *	Inverter trip *	Inverter trip *
		Data communication	Continued	Continued	Continued
	Error of communication option itself	Inverter operation	Inverter trip *	Continued	Continued
		Data communication	Stop	Stop	Stop

* Depends on the *Pr. 502* setting.

(2) Measures at alarm occurrences

Alarm Indication	Alarm Definition	Measures
E.OP1	Communication line error	Check the LED status of the option unit and remove the cause of the alarm. (Refer to <i>page 4</i> for LED indication status) Inspect the master.
E.1	Option alarm	Check the connection between the inverter and option unit for poor contact, etc. and remove the cause of the error.

When alarms other than the above are displayed, refer to the inverter manual and remove the cause of the alarm.

4.6 Inverter Reset

(1) Operation conditions of inverter reset

Which resetting method is allowed or not allowed in each operation mode is described below.

Resetting Method			Operation Mode		
			Network Operation	External Operation	PU Operation
Reset from the network	Inverter reset (Class 0x2A Instance 1 Attribute 101) (Refer to page 71) *1		Allowed	Disallowed	Disallowed
	Error reset at inverter fault (Refer to page 51) *2	Pr.349 = 0	Allowed	Allowed	Allowed
Pr.349 = 1		Disallowed		Disallowed	
Turn on the inverter terminal RES (RES signal)			Enabled	Enabled	Enabled
Switch off inverter power			Enabled	Enabled	Enabled
Reset from the PU/operation panel	Inverter reset		Enabled	Enabled	Enabled
	Reset at inverter fault		Enabled	Enabled	Enabled

*1 Inverter reset can be made any time.

*2 Reset can be made only when the protective function of the inverter is activated.

CAUTION

- When a communication line error has occurred, reset cannot be made from the network.
- The inverter is set to the external operation mode if it has been reset in network operation mode in the initial status.
To resume the network operation, the inverter must be switched to the network operation mode again.
Set a value other than "0" in Pr. 340 to start in network operation mode. (Refer to page 25.)
- The inverter can not be controlled for about 1s after release of a reset command .

(2) Error reset operation selection at inverter fault

When used with the communication option, an error reset command* from network can be made invalid in the external operation mode or PU operation mode.

Parameter Number	Name	Initial Value	Setting Range	Function
349	Communication reset selection	0	0	Error reset* is enabled independently of operation mode
			1	Error reset* is enabled only in the network operation mode

* Class 0x04 Attribute 3 Instance 20, 21, 126 Byte0 Bit2 (Refer to pages 51, 53, 56.)



4.7 Frequency and Speed Conversion Specifications

For frequency setting and monitor from the communication option, frequency is set in 0.01Hz increments and displayed on the monitor regardless of the *Pr. 37 Speed display* setting.

Speed setting and monitor from the communication option are calculated by the following formula.

$$\text{Speed setting, monitor (1r/min increments)} = \text{frequency} \times 120 / \text{number of motor poles (4*)}$$

* Calculated on the assumption that the number of motor poles is 4.

REMARKS

- Refer to the inverter manual for details of *Pr. 37*.

5 FUNCTIONS

5.1 Output from the Inverter to the Network

Main items to be output from the inverter (FR-A7ND) to the network and their descriptions are explained below.

Item	Description	Refer to Page
Inverter monitor	Monitor various items such as inverter output frequency and output current.	77, 87
Operation mode read	Read the operation mode of the inverter.	72
Parameter read	Read parameter settings of the inverter.	79, 84, 86
Inverter status	Monitor the output signal of the inverter.	73
Alarm definition	Monitor the alarm history of the inverter.	72

REMARKS

- Refer to *the inverter manual* for functions controllable from the network in each operation mode.

5.2 Input to the Inverter from the Network

Main items which can be commanded from the network to the inverter and their descriptions are explained below.

Item	Description	Refer to Page
Frequency setting	Set the running frequency of the inverter.	51, 71
Operation mode write	Set the operation mode of the inverter.	72
Run command	Set the control input command such as forward operation signal (STF) and reverse rotation signal (STR).	51, 72
Inverter reset	Reset the inverter.	47, 71
Parameter write	Set parameters of the inverter.	79, 84, 86
Parameter clear	Return parameters to the initial values.	47, 71

REMARKS

- Refer to *the inverter manual* for functions controllable from the network in each operation mode.

6 OBJECT MAP DEFINITIONS

6.1 Object Model of DeviceNet Communication

For DeviceNet communication, each node is modeled as collections of objects (abstraction of particular functions of the products).

The following four terms are used to describe object.

Item	Description
Class	Collections of all objects which have same types of functions. Generalization of object
Instance	Concrete expression of object
Attribute	Expression of object characteristic
Service	Function supported by object or class

The following explains object definitions for use of the FR-A7ND DeviceNet.

For details of the definitions, consult the DeviceNet documentation available from ODVA.

Class	Object Name	Page
0x01	Identity Object	46
0x03	DeviceNet Object	48
0x04	Assembly Object	50
0x05	DeviceNet Connection Object	59
0x28	Motor Data Object	66
0x29	Control Management Object	67
0x2A	AC Drive Object	69

Class	Object Name	Page
0x66	Extended Object I	79
0x67	Extended Object II	84
0x70 to 0x79	Extended Object III	86
0x80	Extended Object IV	87

In the following tables, Get and Set mean:

Get :Read from inverter

Set :Read from inverter

6.2 Response Level

6.2.1 Response level of Polling I/O

(1) Response level of DeviceNet bus

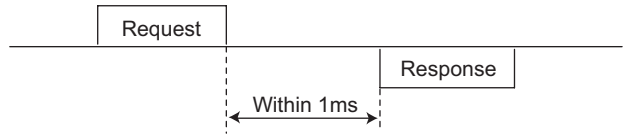

(2) Reflect timing on the actual speed or speed monitor after speed setting

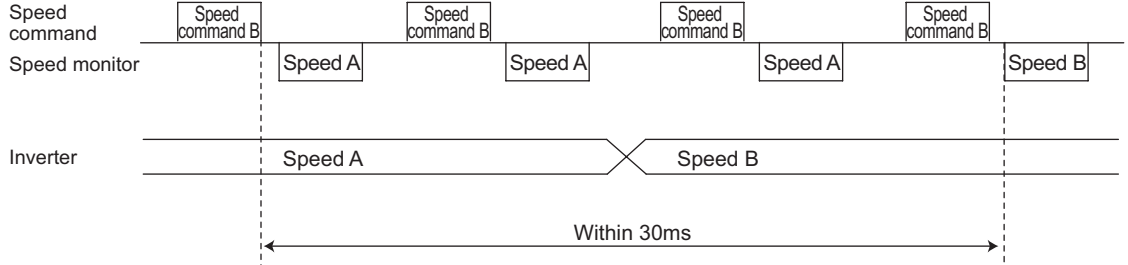

6.2.2 Response level of explicit message

(1) Reading

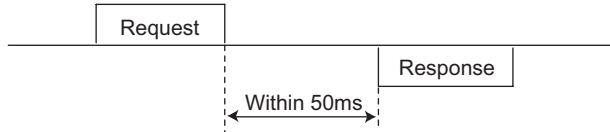

(2) Writing

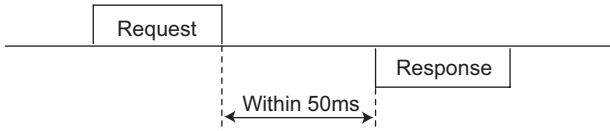

(3) Parameter clearing

The inverter will not respond until parameter clear processing complete (about 5s) after sending parameter all clear command.

6.3 Recommendation for Software Design

Please note the followings when developing designing.

- (1) After sending request to the FR-A7ND, wait for response from the FR-A7ND, then send the next request.
- (2) Set waiting time between each message based on FR-A7ND response time on *page 43*.
For example, after sending a writing request by Explicit message, wait for more than 50ms, then send the next request.

7 OBJECT MAP

7.1 Class 0x01 (Identity-Object)

7.1.1 Class 0x01 Instance 0

(1) Attribute

Attribute ID	Access	Description	Data Length	Attribute Value
1	Get	Revision	Word	1
2	Get	Maximum Instance	Word	1
6	Get	Max Class Attributes	Word	7
7	Get	Max Instance Attributes	Word	7

(2) Service

Service Code	Description
0x0E	Get Attribute Single

7.1.2 Class 0x01 Instance 1

(1) Attribute

Attribute ID	Access	Description	Data Length	Attribute Value
1	Get	Vendor ID (Mitsubishi electric)	Word	161
2	Get	Device Type (AC drive)	Word	02
3	Get	Product Code	Word	49
4	Get	Revision	Struct	1.YYY *1
5	Get	Status	Word	*2
6	Get	Serial Number	Double Word	xxxxxxxx
7	Get	Product Name (FR-E700)	5 Byte	E700 *3

*1 High byte of hexadecimal word data means integer and low byte means decimal.
For example, when the read data is 0x010A, it means version 1.010.

*2 Bit definition

Bit0: 0 = allocated, 1 = not allocated, Bit2: 0, Bit8: 1 = minor fault occurrence, Bit9: 0, Bit10: 1 = LED is flickering red, Bit11: 1 = LED is lit red

*3 As the actual data, 0x04, 0x45, 0x37, 0x30, and 0x30 are stored. 0x04 means 4 byte data and the rest means ASCII code of "E700".

(2) Service

Service Code	Symbol	Name	Setting Range	Description
0x05	Reset	Reset *1	0	Inverter reset *2
			1	Inverter reset after all parameter clear *2
0x0E	Get	Get_Attribute_Single	—	Get Attribute Single

*1 As set in *Pr. 75*. Refer to the inverter manual for details of *Pr. 75*.

*2 Inverter reset and all parameter clear are not performed when the inverter will not accept the order.

7.2 Class 0x03 (DeviceNet Object)

7.2.1 Class 0x03 Instance 1

(1) Attribute

Attribute ID	Access	Name	Initial Value	Setting Range	Description
1	Get/Set	MAC ID *1	*2	00 to 63	Node address value
2	Get/Set	Baud Rate *1	00	00	125kbps
				01	250kbps
				02	500kbps
5	Get	Allocation Information			
		Allocation Choice Byte		0	G2Explicit
				1	Poll
				2	Bit Strobe
				3	Multicast Poll
				4	Change Of State
5	Cyclic				
		Master's MAC ID		0 to 63, 255	Changed with Allocate only.
8	Get	MAC ID Switch Value	00	00 to 63	Node address switch value

*1 Can be read with Class 0x67 Instance 1 Attribute 45 and 46 also. (Refer to page 84.)

*2 The initial value differs according to the node address switch conditions.

(2) Service

Service Code	Service
0x0E	Get Attribute Single
0x10	Set Attribute Single
0x4B	Allocate
0x4C	Release

7.3 Class 0x04 (Assembly Object)

Attribute ID	Access	Name	Initial Value	Data Length	Description
3	Get	Data	—	Byte alignment	Refer to <i>page 51 or later</i> .

Set I/O instance in either of the following methods.

- Pr.346 setting (*Refer to page 22*)
- Class 0x29, Instance 1, Attribute 140, 141 setting (*Refer to page 68*)

Output Instance	Input Instance	Refer to page
20 (4 byte)	70 (4 byte)	51
21 (4 byte)	71 (4 byte)	53
126 (6 byte)	176 (6 byte)	55

* Value in parenthesis is data length.

7.3.1 Output Instance 20/Input Instance 70

1. Output Instance 20 (Master→inverter)

When using Output Instance 20, set Input Instance to 70.

Byte	Bit7	Bit6	Bit5	Bit4	Bit3	Bit2	Bit1	Bit0
0	—	—	—	—	—	Fault Reset	—	Run Fwd
1	—							
2	Speed reference (low byte)							
3	Speed reference (high byte)							

[Output Instance 20 details]

Byte0	Bit0	Run Fwd	Forward rotation signal (0:forward rotation off, 1:forward rotation on)
	Bit2	Fault Reset	Reset request at an error occurrence Valid only at in inverter trip (0:no function, 1:fault reset request)
Byte2 Byte3		Speed Ref	Speed reference (r/min) (Refer to <i>page 40</i> for conversion formula of speed and frequency.)

2. Input Instance 70 (Inverter→master)

When using Input Instance 70, set Output Instance to 20.

Byte	Bit7	Bit6	Bit5	Bit4	Bit3	Bit2	Bit1	Bit0
0	—	—	—	—	—	Running Fwd	—	Faulted
1	00							
2	Speed actual (low byte)							
3	Speed actual (high byte)							

[Input Instance 70 details]

Byte0	Bit0	Faulted	Inverter error signal (0: inverter is under normal operation, 1: inverter is in a fault state)
	Bit2	Running Fwd	Forward rotation (0: other than forward rotation, 1: forward rotation)
Byte2 Byte3		Speed Actual	Actual speed currently operating (r/min) (Refer to <i>page 40</i> for conversion formula of speed and frequency.)

7.3.2 Output Instance 21/Input Instance 71

1. Output Instance 21 (initial value) (Master→inverter)

When using Output Instance 21, set Input Instance to 71.

Byte	Bit7	Bit6	Bit5	Bit4	Bit3	Bit2	Bit1	Bit0
0	—	Net Ref	Net Ctrl	—	—	Fault Reset	Run Rev	Run Fwd
1	—							
2	Speed reference (low byte)							
3	Speed reference (high byte)							

[Output Instance 21 details]

Byte0	Bit0	Run Fwd	Forward rotation signal (0: forward rotation off, 1: forward rotation on)	Control related signals
	Bit1	Run Rev	Reverse rotation signal (0: reverse rotation off, 1: reverse rotation on)	
	Bit2	Fault Reset	Reset request at an error occurrence Valid only at an inverter trip (0:no function, 1:fault reset request)	
	Bit5	NetCtrl	Request permission bit of control related signals (Bit0 to Bit2) 0: Control related signals are invalid (It will not function even if a value is set in each bit). 1: Control related signals are valid (it will not be reflected to Pr. 338).	
	Bit6	NetRef	Request permission bit of speed reference (Byte2, Byte3) 0: Speed related data is invalid (it will not function even if a value is set). 1: Speed related data is valid (it will not be reflected to Pr. 339).	
Byte2 Byte3	Speed Ref	Speed reference (r/min) (Refer to page 40 for conversion formula of speed and frequency.)	Makes valid when NetRef (Bit6) = "1"	

2. Input Instance 71 (initial value) (Inverter→master)

When using Input Instance 71, set Output Instance to 21.

Byte	Bit7	Bit6	Bit5	Bit4	Bit3	Bit2	Bit1	Bit0
0	At Reference	Ref From Net	Ctrl From Net	Ready	Running Rev	Running Fwd	—	Faulted
1	00							
2	Speed actual (low byte)							
3	Speed actual (high byte)							

[Input Instance 71 details]

Byte0	Bit0	Faulted	Inverter error signal (0: inverter is under normal operation 1: inverter is in a fault state)
	Bit2	Running Fwd	Forward rotation (0: other than forward rotation, 1: forward rotation)
	Bit3	Running Rev	Reverse rotation (0: other than reverse rotation, 1: reverse rotation)
	Bit4	Ready	Ready signal (0: operation preparation, 1: operation ready) (Always "1" after power on)
	Bit5	CtrlFromNet	State of operation command source (Run/Stop) (Same definition with Class 0x29 Instance 1 Attribute 15 <i>Refer to page 68</i>) 0: Command is enabled in operation other than network 1: Command is enabled in network operation
	Bit6	RefFromNet	State of speed command source (Same definition with Class 0x2A Instance 1 Attribute 29 <i>Refer to page 70</i>) 0: Command is enabled in operation other than network 1: Command is enabled in network operation
	Bit7	AtReference	Up-to-frequency signal (SU signal) (Same definition with Class 0x2A Instance 1 Attribute 3 <i>Refer to page 69</i>)
Byte2 Byte3	Speed Actual		Actual speed currently operating (r/min) (Refer to <i>page 40</i> for conversion formula of speed and frequency.)

7.3.3 Output Instance 126/Input Instance 176

1. Output Instance 126 (Master→inverter)

When using Output Instance 126, set Input Instance to 176.

Byte	Bit7	Bit6	Bit5	Bit4	Bit3	Bit2	Bit1	Bit0
0	Write Param	Net Ref	Net Ctrl	—	—	Fault Reset	Run Rev	Run Fwd
1	Parameter Instance No.							
2	Speed reference or parameter write data (low byte)							
3	Speed reference or parameter write data (high byte)							
4	Parameter class ID							
5	Parameter attribute ID							

[Output Instance 126 details]

Byte0	Bit0	Run Fwd	Forward rotation signal (0: forward rotation off, 1: forward rotation on)	Control related signals															
	Bit1	Run Rev	Reverse rotation signal (0: reverse rotation off, 1: reverse rotation on)																
	Bit2	Fault Reset	Reset request at an error occurrence Valid only at in inverter trip (0:no function, 1:fault reset request)		Makes valid when NetCtrl (Bit5) = "1"														
	Bit5	NetCtrl	Request permission bit of control related signals (Bit0 to Bit2) 0: Control related signals are invalid (It will not function even if a value is set in each bit.) 1: Control related signals are valid (It will not be reflected to Pr. 338.)																
	Bit6	NetRef	Request permission bit of speed reference (Byte 2, Byte 3) 0: Speed setting value (Byte 2, 3) is invalid (It will not function even if a value is set.) 1: Speed setting value (Byte 2, 3) is valid (It will not reflected to Pr. 339.)																
	Bit7	Write Param	Request permission bit of speed reference or parameter write (Byte 2, Byte 3) 0: Byte 2, 3 are speed reference 1: Byte 2, 3 are written to parameter write data (It is written to parameter class and attribute set with Byte 4, 5.)																
Byte1	Parameter Instance No.	Parameter Instance No. can be specified. When 00 is specified, instance No. is regarded as "1".																	
Byte2 Byte3	Speed Ref or Parameter Write Data	Speed reference (r/min) or parameter write data Selection conditions are determined according to a combination of "NetRef (Bit6)" and "WriteParam (Bit7)". [When speed reference is selected] Refer to <i>page 40</i> for conversion formula of speed and frequency.	<table border="1"> <thead> <tr> <th>Write Param</th> <th>Net Ref</th> <th>Selected Data</th> </tr> </thead> <tbody> <tr> <td>0</td> <td>0</td> <td>—</td> </tr> <tr> <td>0</td> <td>1</td> <td>Speed reference</td> </tr> <tr> <td>1</td> <td>0</td> <td>Parameter write data</td> </tr> <tr> <td>1</td> <td>1</td> <td></td> </tr> </tbody> </table>		Write Param	Net Ref	Selected Data	0	0	—	0	1	Speed reference	1	0	Parameter write data	1	1	
Write Param	Net Ref	Selected Data																	
0	0	—																	
0	1	Speed reference																	
1	0	Parameter write data																	
1	1																		
Byte4	Parameter Class ID	Class ID to access to the inverter parameter (class 0x2A, 0x66, 0x67 etc.)																	
Byte5	Parameter Attribute ID	Attribute ID to access to the inverter parameter																	

2. Input Instance 176 (Inverter→master)

When Input Instance 176 is used, 16 bit parameter data is provided.

When using Input Instance 176, set Output Instance to 126.

Byte	Bit7	Bit6	Bit5	Bit4	Bit3	Bit2	Bit1	Bit0
0	At Reference	Ref From Net	Ctrl From Net	Ready	Running Rev	Running Fwd	Run command mode	Faulted
1	PrEnd	00						
2	Speed actual (low byte)							
3	Speed actual (high byte)							
4	Parameter read data (low byte)							
5	Parameter read data (high byte)							

[Input Instance 176 details]

Byte0	Bit0	Faulted	Inverter error signal (0: inverter is under normal operation, 1: inverter is in a fault state)
	Bit1	Run Command Mode *	0: Command is disabled in network operation 1: Command is enabled in network operation
	Bit2	Running Fwd	Forward rotation (0: other than forward rotation, 1: forward rotation)
	Bit3	Running Rev	Reverse rotation (0: other than reverse rotation, 1: reverse rotation)
	Bit4	Ready	Ready signal (0: operation preparation, 1: operation ready) (Always "1" after power on)
	Bit5	CtrlFromNet	State of operation command source (Run/Stop) (Same definition with Class 0x29 Instance 1 Attribute 15 <i>Refer to page 68</i>) 0: Command is enabled in operation other than network 1: Command is enabled in network operation
	Bit6	RefFromNet	State of speed command source (Same definition with Class 0x2A Instance 1 Attribute 29 <i>Refer to page 70</i>) 0: Command is enabled in operation other than network 1: Command is enabled in network operation
Bit7	AtReference	Up-to-frequency signal (SU signal) (Same definition with Class 0x2A Instance 1 Attribute 3 <i>Refer to page 69</i>)	
Byte1	Bit7	PrEnd	Parameter write is completed 0: Parameter write is not performed 1: During parameter write processing (during inverter processing) (This bit may change to 1 during Explicit message processing.)
Byte2 Byte3		Speed Actual	Actual speed currently operating (r/min) (Refer to <i>page 40</i> for conversion formula of speed and frequency.)
Byte4 Byte5		Parameter Read Data	Parameter write data specified by parameter class ID and parameter attribute ID of output instance 126 is read. (<i>Refer to page 56</i>)

*Bit status in the run command mode is as follows. (For the operation/speed command source, refer to *page 29*.)

Inverter Status			Run Command Mode
Operation Mode	Pr. 338	Pr. 339	
NET	0: NET	0: NET	1
	0: NET	1: External	
	1: External	0: NET	0
	1: External	1: External	
Other than NET	—	—	

7.4 Class 0x05 (DeviceNet Connection Object)

FR-A7ND supports only Polling I/O and Explicit message, not Bit-Strobed I/O. In addition, Instance 4 to 6 are Explicit message Instance.

7.4.1 Class 0x05 Instance 1 Attribute (Explicit message connection)

Class 0x05 Instance 1

Attribute ID	Access	Name	Range	Definition
1	Get	State	00	Non-existent
			03	Established
			05	Deferred Delete
2	Get	Instance Type	00	Explicit message connection
3	Get	Transport Trigger Class	00 to 0xFF	0x83: Server Transport Class 3
4	Get	Produced Connection ID	0 to 0xFFFF	(Example) 0x0740 Group 3 Explicit response message of Slave Source MAC ID = 0 The value to be specified in the CAN Identifier Field when this connection transmits
5	Get	Consumed Connection ID	0 to 0xFFFF	(Example) 0x0780 Group 3 Explicit request message of Master Destination MAC ID = 0 The value distinguishes the received messages. The value will be specified in the CAN Identifier Field of messages that are to be consumed.
6	Get	Initial Command Characteristics	00 to 0xFF	The value defines sent and received message groups. 0x21: Both send and receive messages are Group 2 message
7	Get	Produced Connection Size	0 to 0xFFFF	This value specifies the maximum number of Message Body bytes that a module is able to transmit across the connection. 7: 7 byte

Class 0x05 Instance 1

Attribute ID	Access	Name	Range	Definition
8	Get	Consumed Connection Size	0 to 0xFFFF	This value specifies the maximum number of Message Body bytes that a module is able to receive across the connection. 7: 7 byte
9	Get/Set	Expected Pack Rate (EPR)	0 to 0xFFFF	(Example) 2500: 2500ms
12	Get/Set	Watchdog Action	00	Invalid
			01	Auto Delete (Initial value)
			02	Invalid
			03	Deferred Delete
13	Get	Produced Connection Path Length	0 to 0xFFFF	Specifies the number of bytes of information within the produced_connection_path attribute. (always 0)
14	Get	Produced Connection Path	Variable	Free
15	Get	Consumed Connection Path Length	0	Specifies the number of bytes of information within the produced_connection_path attribute. (always 0)
16	Get	Consumed Connection Path	Variable	Free

7.4.2 Class 0x05 Instance 2 Attribute (Polling I/O connection)

Class 0x05 Instance 2

Attribute ID	Access	Name	Range	Definition
1	Get	State	00	Non-existent
			01	Configuring
			03	Established
			04	Timed out
2	Get	Instance Type	01	Polling I/O connection
3	Get	Transport Trigger Class	00 to 0xFF	0x82: Server Transport Class 2
4	Get	Produced Connection ID	0 to 0xFFFF	(Example) 0x03C0 Group 1 Polling I/O response message of Slave Source MAC ID = 0 The value to be placed in the CAN Identifier Field when this connection transmits
5	Get	Consumed Connection ID	0 to 0xFFFF	(Example) 0x0405 Group 2 Polling I/O command message of Master Destination MAC ID = 0 The value distinguishes the receive messages. The value will be specified in the CAN Identifier Field of messages that are to be consumed.
6	Get	Initial Command Characteristics	00 to 0xFF	Source: Group 1 Message Destination: Group 2 Message
7	Get	Produced Connection Size	0 to 0xFFFF	Maximum amount of I/O data transmittable 4: Assembly Instance 70,71 6: Assembly Instance 176
8	Get	Consumed Connection Size	0 to 0xFFFF	Maximum amount of I/O data receivable 4: Assembly Instance 20,21 6: Assembly Instance 126

Class 0x05 Instance 2

Attribute ID	Access	Name	Range	Definition
9	Get/Set	Expected Packet Rate (EPR)	0 to 0xFFFF	(Example) 2500: 2500ms
12	Get/Set	Watchdog Action	0	Transition to time out (initial value)
			1	Auto Delete
			2	Auto reset
13	Get	Produced Connection Path Length	0 to 0xFFFF	Specifies the number of bytes of information within the produced_connection_path attriburte
14	Get	Produced Connection Path	00 to 0xFF	The value specifies Application Object of sent data. *1 0x62, 0x34, 0x36: Assmby Instance 70 0x62, 0x34, 0x37: Assmby Instance 71 0x62, 0x42, 0x30: Assembly Instance 176
15	Get	Consumed Connection Path Length	0 to 0xFFFF	Specifies the number of bytes of information within the consumed_connection_path attriburte 3: 3 byte
16	Get	Consumed Connection Path	00 to 0xFF	The value specifies Application Object of received data. *1 0x62, 0x31, 0x34: Assmby Instance 20 0x62, 0x31, 0x35: Assmby Instance 21 0x62, 0x37, 0x45: Assmby Instance 126

- *1 Since 2byte data is sent and received for Polling I/O message communication, the lowest byte is 0x00. Produced Connection Path and Consumed Connection Path specifies Application Object of sent and received data. The format is below.

0x62
0xMM
0xNN

|
|
|

Logic address Application Object data

This is ASCII Code which shows input/output instance value (hexadecimal).

(Example) When Output Instance 21 and Input Instance 71 are used as sent and receive data

(a) Produced Connection Path (send data)	(a) Consumed Connection Path (receive data)
Input Instance 71 = 0x47 ASCII code: 4 = 034, 7 = 037 Therefore, Produced Connection Path = 0x62 0x34 0x37	Output Instance 21 = 0x15 ASCII code: 1 = 0x31, 5 = 0x35 Therefore, Consumed Connection Path = 0x62 0x31 0x35

For changing Input Output Assembly, refer to *page 67*.

7.4.3 Class 0x05 Instance 4, 5, 6 Attribute (Explicit message connection)

Class 0x05 Instance 4, 5, 6

Attribute ID	Access	Name	Range	Definition
1	Get	State	00	Non-existent
			03	Established
			05	Deferred Delete
2	Get	InstanceType	00	Explicit message connection
3	Get	Transport Trigger Class	00 to 0xFF	0x83: Server Transport Class 3
4	Get	Produced Connection ID	0 to 0xFFFF	(Example) 0x0740 Group 3 Explicit response message of Slave Source MAC ID = 0 The value to be placed in the CAN Identifier Field when this connection transmits
5	Get	Consumed Connection ID	0 to 0xFFFF	(Example) 0x0780 Group 3 Explicit request message of Master Destination MAC ID = 0 The value distinguishes the received messages. The value will be specified in the CAN Identifier Field of messages that are to be consumed.
6	Get	Initial Command Characteristics	00 to 0xFF	The value defines sent and received message groups. 0x33: Both send and receive messages are Group 2 message
7	Get	Produced Connection Size	0 to 0xFFFF	This value specifies the maximum number of Message Body bytes that a module is able to transmit across the connection. 7: 7 byte
8	Get	Consumed Connection Size	0 to 0xFFFF	This value specifies the maximum number of Message Body bytes that a module is able to receive across the connection. 7: 7 byte

Class 0x05 Instance 4, 5, 6

Attribute ID	Access	Name	Range	Definition
9	Get/Set	Expected Pack Rate (EPR)	0 to 0xFFFF	(Example) 2500: 2500ms
12	Get/Set	Watchdog Action	00	Invalid
			01	Auto Delete (Initial value)
			02	Invalid
			03	Deferred Delete
13	Get	Produced Connection Path Length	0 to 0xFFFF	Specifies the number of bytes of information within the produced_connection_path attribute. (always 0)
14	Get	Produced Connection Path	Variable	Free
15	Get	Consumed Connection Path Length	0	Specifies the number of bytes of information within the consumed_connection_path attribute. (always 0)
16	Get	Consumed Connection Path	Variable	Free

7.4.4 Class 0x05 Instance 1, 2, 4, 5, 6 service

Service Code	Definition
0x0E	Get Attribute Single
0x10	Set Attribute Single

7.5 Class 0x28 (Motor Data Object)

7.5.1 Class 0x28 Instance 1

(1) Attribute

Attribute ID	Access	Name	Range	Description
3	Get/Set	Motor type	7	Squirrel-cage induction motor (fixed value)
6	Get/Set	Rated motor current (<i>Pr. 9</i>)	0 to 0xFFFF	[GET] Return the <i>Pr. 9</i> setting in 0.1A increments. [SET] Write the value to <i>Pr. 9</i> in 0.1A increments.
7	Get/Set	Rated voltage (<i>Pr. 19</i>)	0 to 0xFFFF	[GET] · When <i>Pr. 19</i> = "9999" or "8888", return "200" for the 200V class and "400" for the 400V class. · When <i>Pr. 19</i> = "0 to 1000", return the <i>Pr. 19</i> setting. (decimal places are rounded) [SET] "0 to 1000", "65535(9999)", "65520(8888)" can be set.

(2) Service

Service Code	Description
0x0E	Get Attribute Single
0x10	Set Attribute Single

7.6 Class 0x29 (Control Supervisor Object)

7.6.1 Class 0x29 Instance 1

(1) Attribute

Class 0x29 Instance 1

Attribute ID	Access	Name	Initial Value	Range	Description
3	Get/Set	RUN1	00	0	Stop
				1	Forward rotation
4	Get/Set	RUN2	00	0	Stop
				1	Reverse rotation
5	Get/Set	NetCtrl (operation command source) <i>(Pr. 338)</i>	1	0	Other than DeviceNet communication operation
				1	DeviceNet communication operation
6	Get	State	3	1	Startup
				2	Not_Ready (during reset)
				3	Ready (during stop)
				4	Enabled (during acceleration, during constant speed, during reverse deceleration)
				5	Stopping (during deceleration)
				6	Fault_Stop (during deceleration with <i>Pr. 502</i>)
				7	Faulted (during alarm occurrence)
7	Get	Running 1 (forward rotation command)	0	0	During stop
				1	During forward rotation
8	Get	Running 2 (reverse rotation command)	0	0	During stop
				1	During reverse rotation

Class 0x29 Instance 1

Attribute ID	Access	Name	Initial Value	Range	Description
9	Get	Ready	1	0	During reset or alarm occurrence
				1	Stop or running
10	Get	Faulted	0	0	No fault present
				1	Fault occurred (latched)
12	Get/Set	FaultRst (fault reset) *1	0	0	Reset release at fault occurrence
				1	Reset execution at fault occurrence
15	Get	CtrlFromNet (operation command source monitor) *2	1	0	Other than DeviceNet communication operation
				1	DeviceNet communication operation
140	Get/Set	Instance ID of Input Assembly *2, *3	0x47 (71)	0x46	Input Instance 70
				0x47	Input Instance 71
				0xB0	Input Instance 176
141	Get/Set	Instance ID of Output Assembly *2, *4	0x15 (21)	0x14	Output Instance 20
				0x15	Output Instance 21
				0x7E	Output Instance 126

*1 After reset with 01 set, this value must be set to 00 before inverter reset may be performed.

*2 This data is only updated after inverter reset or power-on reset.

*3 When this ID is set, it is reflected to bit7 to 11 of Pr: 346 and Class 0x05 Instance 2 Attribute 7, 13, 14 .

*4 When this ID is set, it is reflected to bit2 to 6 of Pr: 346 and Class 0x05 Instance 2 Attribute 8, 15, 16 .

(2) Service

Service Code	Description
0x0E	Get Attribute Single
0x10	Set Attribute Single

7.7 Class 0x2A (AC Drive Object)

7.7.1 Class 0x2A Instance 1

(1) Attribute

Class 0x2A Instance 1

Attribute ID	Access	Name	Range	Description
3	Get	AtReference (up to frequency)	0	Output frequency has not reached the set frequency
			1	Output frequency has reached the set frequency
4	Get/Set	NetRef (operation command source) (Pr. 339)	0	Other than DeviceNet communication operation (Pr. 339 = "1")
			1	DeviceNet communication operation (Pr. 339 = "0")
6	Get	DriveMode (operation mode)	0	Always 0
7	Get	SpeedActual (actual speed)	0 to 32767r/min	The output frequency converted to speed is returned. (1r/min increments) (Refer to <i>page 40</i> for conversion formula of speed and frequency.)
8	Get/Set	SpeedRef (speed setting value)	0 to 32767r/min	Set speed (1r/min increments) (Refer to <i>page 40</i> for conversion formula of speed and frequency.)

Class 0x2A Instance 1

Attribute ID	Access	Name	Range	Description
9	Get	CurrentActual (actual current)	0 to 3276.7A	The output current is monitored in 0.1A increments.
15	Get	PowerActual (actual power)	0 to 65535W	Output power is monitored in 1W increments.
17	Get	OutputVoltage (output voltage)	0 to 32767V	The output voltage is monitored in 1V increments.
18	Get/Set	AccelTime (acceleration time)	0 to 65535ms	Acceleration time = $Pr. 7 \times (Pr. 1 / Pr. 20)$ Set the increments in ms regardless of the <i>Pr. 21</i> setting.
19	Get/Set	DecelTime (deceleration time)	0 to 65535ms	Acceleration time = $Pr. 8 \times (Pr. 1 / Pr. 20)$ Set the increments in ms regardless of the <i>Pr. 21</i> setting.
20	Get/Set	LowSpdLimit (minimum frequency) <i>(Pr. 2)</i>	0 to 65535r/min	Minimum speed (1r/min increments) (Refer to <i>page 40</i> for conversion formula of speed and frequency.)
21	Get/Set	HighSpdLimit (maximum frequency) <i>(Pr. 1)</i>	0 to 65535r/min	Maximum speed (1r/min increments) (Refer to <i>page 40</i> for conversion formula of speed and frequency.)
29	Get	RefFromNet (speed command source monitor)	0	Other than DeviceNet communication operation
			1	DeviceNet communication operation

Class 0x2A Instance 1

Attribute ID	Access	Range	Description	
101	Set	Any	Inverter reset Set a value other than "0" in Pr. 340 to start in network operation mode after reset. (Refer to page 25) *1	
102	Set	0x965A	Parameter clear *1	
103	Set	0x99AA	All parameter clear *1	
105	Set	0x5A96	Clear parameters *1	Communication parameters are not cleared. (Parameters for FR-A7ND (Pr. 345, Pr. 346) are cleared.)
106	Set	0xAA99	All parameter clear *1	
112	Get/Set	0 to 0x9C40	Set frequency (RAM) *2	Either write the set frequency to RAM or read from RAM. (0.01Hz increments)
113	Set	0 to 0x9C40	Set frequency (EEPROM) *2	Write the set frequency to EEPROM (0.01Hz increments)

*1 Error response is returned when the inverter will not accept the order.

*2 The data written to Attribute 112, 113 can be read from Attribute 112.

Class 0x2A Instance 1

Attribute ID	Access	Range	Description
114	Get/Set	—	Inverter status monitor/run command (<i>Refer to page 73</i>)
120	Get/Set	0	External operation
		1	PU operation
		2	External jog operation
		3	PU jog operation
		4	Network operation
		5	External/PU combined operation
		0x0010	External operation
		0x0011	PU operation (when <i>Pr: 79 = 6</i>)
		0x0014	Network operation
141	Get/Set	—	Alarm definition (latest alarm) Alarm definition all clear ·
142	Get	—	Alarm definition 2 (second alarm in past)
143	Get	—	Alarm definition 3 (third alarm in past)
144	Get	—	Alarm definition 4 (fourth alarm in past)
145	Get	—	Alarm definition 5 (fifth alarm in past)
146	Get	—	Alarm definition 6 (sixth alarm in past)
147	Get	—	Alarm definition 7 (seventh alarm in past)
148	Get	—	Alarm definition 8 (eighth alarm in past)

* Writing any value will clear the alarm definition.

Bit map of inverter status monitor/running command is as follows.

● Inverter status monitor (Get)

Bit	Signal	Descriptio
0	Running (RUN signal)	On : Inverter output frequency reaches or exceeds <i>Pr.13 Starting frequency</i> .
1	During forward rotation	OFF : Other than forward rotation (stop, reverse rotation) ON : During forward rotation
2	During reverse rotation	OFF : Other than reverse rotation (stop, forward rotation) ON : During reverse rotation
3	Up to frequency (SU signal)	ON : Output frequency has reached the set frequency
4	Overload alarm (OL signal)	ON : Overload alarm occurrence
5	— (Not used)	(Always 0)
6	Frequency detection (FU signal)	ON : Output frequency reaches or exceeds the frequency set in <i>Pr. 42 (Pr. 43 for reverse rotation)</i> .
7	Alarm (ALM signal)	ON : Output when the inverter protective function is activated to stop the output (major fault).
8 to 14	— (Not used)	(Always 0)
15	Inverter operation ready (RY signal)	ON : Output reset process is completed (when the inverter can be started by switching the start signal on or while it is running) after powering on the inverter.

● Run command (Set)

Bit	Signal	Description	
0	— (Not used)	(Always 0)	
1	Forward rotation command *2	OFF : Stop command ON : Forward rotation start	A starting command is input to the inverter when the signal turns on. A stop command is given when both signals turn on simultaneously.
2	Reverse rotation command *2	OFF : Stop command ON : Reverse rotation start	
3	High speed operation command (terminal RH function) *1	Functions assigned to terminal RH, RM and RL are activated.	
4	Middle speed operation command (terminal RM function) *1		
5	Low speed operation command (terminal RL function) *1		
6	— (Not used)	(Always 0)	
7	Second function selection (RT signal) *3	ON : Second function is selected.	
8	Terminal 4 input selection (AU signal) *3	ON : Terminal 4 input is the main speed.	
9	— (Not used)	(Always 0)	
10	Output stop (terminal MRS function) *1	Functions assigned to terminal MRS are activated.	
11	— (Not used)	(Always 0)	
12	Reset (terminal RES function) *1	Functions assigned to terminal RES are activated.	
13 to 15	— (Not used)	(Always 0)	

- *1 Signal names are initial values. Using *Pr. 180 to Pr.184*, you can change input signal functions. Note that some of signals do not accept a command from the network according to the *Pr. 338 and Pr. 339* settings. For example, reset (terminal RES function) of Bit12 can not be controlled via the network. (*refer to page 29*)
Refer to the inverter manual for details of *Pr. 180 to Pr.184*.
- *2 Signals of the Bit1 and Bit2 can not be changed. Even if signals are changed using *Pr. 178 and Pr. 179*, the settings are invalid.
Refer to the inverter manual for details of *Pr. 178 and Pr.179*.
When using polling I/O message together, do not use start command (forward rotation, reverse rotation) of polling. (Turn off Bit5 (NetCtrl) of Byte0.)
Use start command of Class 0x2A, instance 1, attribute 114 stated in the table for start command (forward rotation/reverse rotation).
- *3 Signals of the Bit7 and Bit8 can not be changed.

● List of alarm definition

Refer to the inverter manual for details of alarm definitions.

Data	Definition
0x00	No alarm
0x10	OC1
0x11	OC2
0x12	OC3
0x20	OV1
0x21	OV2
0x22	OV3
0x30	THT
0x31	THM
0x40	FIN
0x52	ILF
0x60	OLT
0x70	BE
0x80	GF
0x81	LF
0x90	OHT
0xA1	OP1

Data	Definition
0xB0	PE
0xB1	PUE
0xB2	RET
0xB3	PE2
0xC0	CPU
0xC5	IOH
0xC7	AIE
0xC8	USB
0xD8	MB4
0xD9	MB5
0xDA	MB6
0xDB	MB7
0xF1	E.1
0xF6	E.6
0xF7	E.7
0xFD	E.13

Class 0x2A Instance 1

Attribute ID	Access	Description (Increments)
170	Get	Output frequency (0.01Hz)
171	Get	Output current (0.01A)
172	Get	Output voltage (0.1V)
174	Get	Frequency setting (0.01Hz)
176	Get	Motor torque (0.1%)
177	Get	Converter output voltage (0.1V)
178	Get	Regenerative brake duty (0.1%)
179	Get	Electronic thermal relay function load factor (0.1%)
180	Get	Output current peak value(0.01A)
181	Get	Converter output voltage peak value (0.1V)
183	Get	Output voltage (0.01kW)
184	Get	Input terminal status *1
185	Get	Output terminal status *2
189	Get	Cumulative energization time (1h)
192	Get	Actual operation time (1h)
193	Get	Motor load factor (0.1%)
194	Get	Cumulative power (1kWh)

*1 Input terminal monitor details

b15														b0	
—	—	—	—	—	RES	—	MRS	—	RH	RM	RL	—	—	STR	STF

*2 Output terminal monitor details

b15														b0	
—	—	—	—	—	—	—	—	—	—	ABC	FU	—	—	—	RUN

(2) Service

Service Code	Description
0x0E	Get Attribute Single
0x10	Set Attribute Single

7.8 Class 0x66 (Extended Object I)

7.8.1 Class 0x66 Instance 1

Set parameters of the inverter. Refer to the inverter manual for details of the parameters.

REMARKS

- When reading/writing parameter, Class 0x70 to 0x79 (Extended object III) is recommended. (Refer to page 86)

(1) Attribute

Class 0x66 Instance 1

Attribute ID	Parameters	Access	Name
10	Pr. 0	Get/Set	Torque boost
11	Pr. 1	Get/Set	Maximum frequency
12	Pr. 2	Get/Set	Minimum frequency
13	Pr. 3	Get/Set	Base frequency
14	Pr. 4	Get/Set	Multi-speed setting (high speed)
15	Pr. 5	Get/Set	Multi-speed setting (middle speed)
16	Pr. 6	Get/Set	Multi-speed setting (low speed)
17	Pr. 7	Get/Set	Acceleration time
18	Pr. 8	Get/Set	Deceleration time
19	Pr. 9	Get/Set	Electronic thermal O/L relay
20	Pr. 10	Get/Set	DC injection brake operation frequency
21	Pr. 11	Get/Set	DC injection brake operation time
22	Pr. 12	Get/Set	DC injection brake operation voltage

Class 0x66 Instance 1

Attribute ID	Parameters	Access	Name
23	Pr. 13	Get/Set	Starting frequency
24	Pr. 14	Get/Set	Load pattern selection
25	Pr. 15	Get/Set	Jog frequency
26	Pr. 16	Get/Set	Jog acceleration/deceleration time
27	Pr. 17	Get/Set	MRS input selection
28	Pr. 18	Get/Set	High speed maximum frequency
29	Pr. 19	Get/Set	Base frequency voltage
30	Pr. 20	Get/Set	Acceleration/deceleration reference frequency
31	Pr. 21	Get/Set	Acceleration/deceleration time increments
32	Pr. 22	Get/Set	Stall prevention operation level
33	Pr. 23	Get/Set	Stall prevention operation level compensation factor at double speed
34	Pr. 24	Get/Set	Multi-speed setting (speed 4)
35	Pr. 25	Get/Set	Multi-speed setting (speed 5)

Class 0x66 Instance 1

Attribute ID	Parameters	Access	Name
36	<i>Pr. 26</i>	Get/Set	Multi-speed setting (speed 6)
37	<i>Pr. 27</i>	Get/Set	Multi-speed setting (speed 7)
39	<i>Pr. 29</i>	Get/Set	Acceleration/deceleration pattern selection
40	<i>Pr. 30</i>	Get/Set	Regenerative function selection
41	<i>Pr. 31</i>	Get/Set	Frequency jump 1A
42	<i>Pr. 32</i>	Get/Set	Frequency jump 1B
43	<i>Pr. 33</i>	Get/Set	Frequency jump 2A
44	<i>Pr. 34</i>	Get/Set	Frequency jump 2B
45	<i>Pr. 35</i>	Get/Set	Frequency jump 3A
46	<i>Pr. 36</i>	Get/Set	Frequency jump 3B
47	<i>Pr. 37</i>	Get/Set	Speed display
50	<i>Pr. 40</i>	Get/Set	RUN key rotation direction selection
51	<i>Pr. 41</i>	Get/Set	Up-to-frequency sensitivity
52	<i>Pr. 42</i>	Get/Set	Output frequency detection
53	<i>Pr. 43</i>	Get/Set	Output frequency detection for reverse rotation
54	<i>Pr. 44</i>	Get/Set	Second acceleration/ deceleration time
55	<i>Pr. 45</i>	Get/Set	Second deceleration time
56	<i>Pr. 46</i>	Get/Set	Second torque boost
57	<i>Pr. 47</i>	Get/Set	Second V/F (base frequency)
58	<i>Pr. 48</i>	Get/Set	Second stall prevention operation current
61	<i>Pr. 51</i>	Get/Set	Second electronic thermal O/ L relay

Class 0x66 Instance 1

Attribute ID	Parameters	Access	Name
62	<i>Pr. 52</i>	Get/Set	DU/PU main display data selection
64	<i>Pr. 54</i>	Get/Set	FM terminal function selection
65	<i>Pr. 55</i>	Get/Set	Frequency monitoring reference
66	<i>Pr. 56</i>	Get/Set	Current monitoring reference
67	<i>Pr. 57</i>	Get/Set	Restart coasting time
68	<i>Pr. 58</i>	Get/Set	Restart cushion time
69	<i>Pr. 59</i>	Get/Set	Remote function selection
70	<i>Pr. 60</i>	Get/Set	Energy saving control selection
71	<i>Pr. 61</i>	Get/Set	Reference current
72	<i>Pr. 62</i>	Get/Set	Reference value at acceleration
73	<i>Pr. 63</i>	Get/Set	Reference value at deceleration
75	<i>Pr. 65</i>	Get/Set	Retry selection
76	<i>Pr. 66</i>	Get/Set	Stall prevention operation reduction starting frequency
77	<i>Pr. 67</i>	Get/Set	Number of retries at fault occurrence
78	<i>Pr. 68</i>	Get/Set	Retry waiting time
79	<i>Pr. 69</i>	Get/Set	Retry count display erase
80	<i>Pr. 70</i>	Get/Set	Special regenerative brake duty
81	<i>Pr. 71</i>	Get/Set	Applied motor
82	<i>Pr. 72</i>	Get/Set	PWM frequency selection
83	<i>Pr. 73</i>	Get/Set	Analog input selection
84	<i>Pr. 74</i>	Get/Set	Input filter time constant

Class 0x66 Instance 1

Attribute ID	Parameters	Access	Name
85	<i>Pr. 75</i>	Get/Set	Reset selection/disconnected PU detection/PU stop selection
87	<i>Pr. 77</i>	Get	Parameter write selection
88	<i>Pr. 78</i>	Get/Set	Reverse rotation prevention selection
89	<i>Pr. 79</i>	Get	Operation mode selection
90	<i>Pr. 80</i>	Get/Set	Motor capacity
91	<i>Pr. 81</i>	Get/Set	Number of motor poles
92	<i>Pr. 82</i>	Get/Set	Motor excitation current
93	<i>Pr. 83</i>	Get/Set	Motor rated voltage
94	<i>Pr. 84</i>	Get/Set	Rated motor frequency
99	<i>Pr. 89</i>	Get/Set	Speed control gain (magnetic flux vector)
100	<i>Pr. 90</i>	Get/Set	Motor constant (R1)
101	<i>Pr. 91</i>	Get/Set	Motor constant (R2)
102	<i>Pr. 92</i>	Get/Set	Motor constant (L1)
103	<i>Pr. 93</i>	Get/Set	Motor constant (L2)
104	<i>Pr. 94</i>	Get/Set	Motor constant (X)
106	<i>Pr. 96</i>	Get/Set	Auto tuning setting/status
127	<i>Pr. 117</i>	Get/Set	PU communication station number
128	<i>Pr. 118</i>	Get/Set	PU communication speed
129	<i>Pr. 119</i>	Get/Set	PU communication stop bit length
130	<i>Pr. 120</i>	Get/Set	PU communication parity check

Class 0x66 Instance 1

Attribute ID	Parameters	Access	Name
131	<i>Pr. 121</i>	Get/Set	Number of PU communication retries
132	<i>Pr. 122</i>	Get/Set	PU communication check time interval
133	<i>Pr. 123</i>	Get/Set	PU communication waiting time setting
134	<i>Pr. 124</i>	Get/Set	PU communication CR/LF selection
135	<i>Pr. 125</i>	Get/Set	Terminal 2 frequency setting gain frequency
136	<i>Pr. 126</i>	Get/Set	Terminal 4 frequency setting gain frequency
137	<i>Pr. 127</i>	Get/Set	PID control automatic switchover frequency
138	<i>Pr. 128</i>	Get/Set	PID action selection
139	<i>Pr. 129</i>	Get/Set	PID proportional band
140	<i>Pr. 130</i>	Get/Set	PID integral time
141	<i>Pr. 131</i>	Get/Set	PID upper limit
142	<i>Pr. 132</i>	Get/Set	PID lower limit
143	<i>Pr. 133</i>	Get/Set	PID action set point
144	<i>Pr. 134</i>	Get/Set	PID differential time
155	<i>Pr. 145</i>	Get/Set	PU display language selection
156	<i>Pr. 146</i>	Get/Set	Built-in potentiometer switching
157	<i>Pr. 147</i>	Get/Set	Acceleration/deceleration time switching frequency
160	<i>Pr. 150</i>	Get/Set	Output current detection level

Class 0x66 Instance 1

Attribute ID	Parameters	Access	Name
161	<i>Pr. 151</i>	Get/Set	Output current detection signal delay time
162	<i>Pr. 152</i>	Get/Set	Zero current detection level
163	<i>Pr. 153</i>	Get/Set	Zero current detection time
166	<i>Pr. 156</i>	Get/Set	Stall prevention operation selection
167	<i>Pr. 157</i>	Get/Set	OL signal output timer
170	<i>Pr. 160</i>	Get/Set	User group read selection
171	<i>Pr. 161</i>	Get/Set	Frequency setting/key lock operation selection
172	<i>Pr. 162</i>	Get/Set	Automatic restart after instantaneous power failure selection
175	<i>Pr. 165</i>	Get/Set	Stall prevention operation level for restart
178	<i>Pr. 168</i>	Get/Set	Parameter for manufacturer setting (Do not set.)
179	<i>Pr. 169</i>		
180	<i>Pr. 170</i>	Get/Set	Watt-hour meter clear
181	<i>Pr. 171</i>	Get/Set	Operation hour meter clear
182	<i>Pr. 172</i>	Get/Set	User group registered display/batch clear
183	<i>Pr. 173</i>	Get	User group registration
184	<i>Pr. 174</i>	Get	User group clear
188	<i>Pr. 178</i>	Get/Set	STF terminal function selection
189	<i>Pr. 179</i>	Get/Set	STR terminal function selection
190	<i>Pr. 180</i>	Get/Set	RL terminal function selection
191	<i>Pr. 181</i>	Get/Set	RM terminal function selection

Class 0x66 Instance 1

Attribute ID	Parameters	Access	Name
192	<i>Pr. 182</i>	Get/Set	RH terminal function selection
193	<i>Pr. 183</i>	Get/Set	MRS terminal function selection
194	<i>Pr. 184</i>	Get/Set	RES terminal function selection
200	<i>Pr. 190</i>	Get/Set	RUN terminal function selection
201	<i>Pr. 191</i>	Get/Set	FU terminal function selection
202	<i>Pr. 192</i>	Get/Set	A,B,C terminal function selection
212	<i>Pr. 232</i>	Get/Set	Multi-speed setting (speed 8)
213	<i>Pr. 233</i>	Get/Set	Multi-speed setting (speed 9)
214	<i>Pr. 234</i>	Get/Set	Multi-speed setting (speed 10)
215	<i>Pr. 235</i>	Get/Set	Multi-speed setting (speed 11)
216	<i>Pr. 236</i>	Get/Set	Multi-speed setting (speed 12)
217	<i>Pr. 237</i>	Get/Set	Multi-speed setting (speed 13)
218	<i>Pr. 238</i>	Get/Set	Multi-speed setting (speed 14)
219	<i>Pr. 239</i>	Get/Set	Multi-speed setting (speed 15)
220	<i>Pr. 240</i>	Get/Set	Soft-PWM operation selection
221	<i>Pr. 241</i>	Get/Set	Analog input display unit switchover
224	<i>Pr. 244</i>	Get/Set	Cooling fan operation selection
225	<i>Pr. 245</i>	Get/Set	Rated slip
226	<i>Pr. 246</i>	Get/Set	Slip compensation time constant
227	<i>Pr. 247</i>	Get/Set	Constant-power range slip compensation selection
230	<i>Pr. 250</i>	Get/Set	Stop selection

Class 0x66 Instance 1

Attribute ID	Parameters	Access	Name
231	<i>Pr. 251</i>	Get/Set	Output phase loss protection selection
235	<i>Pr. 255</i>	Get	Life alarm status display
236	<i>Pr. 256</i>	Get	Inrush current limit circuit life display
237	<i>Pr. 257</i>	Get	Control circuit capacitor life display
238	<i>Pr. 258</i>	Get	Main circuit capacitor life display
239	<i>Pr. 259</i>	Get	Main circuit capacitor life measuring
241	<i>Pr. 261</i>	Get/Set	Power failure stop selection
247	<i>Pr. 267</i>	Get/Set	Terminal 4 input selection
248	<i>Pr. 268</i>	Get/Set	Monitor decimal digits selection
249	<i>Pr. 269</i>	Get/Set	Parameter for manufacturer setting (Do not set.)

REMARKS

- Values "8888" and "9999" displayed on the parameter unit indicate 65520 (0xFFFF0) and 65535 (0xFFFFF) respectively.

(2) Service

Service Code	Description
0x0E	Get Attribute Single
0x10	Set Attribute Single

7.9 Class 0x67 (Extended Object II)

7.9.1 Class 0x67 Instance 1

Set parameters of the inverter. Refer to the inverter manual for details of the parameters.

REMARKS

- When reading/writing parameter, Class 0x70 to 0x79 (Extended object III) is recommended. (Refer to page 86)

(1) Attribute

Attribute ID	Parameters	Access	Name
10	Pr. 270	Get/Set	Stop-on contact control selection
15	Pr. 275	Get/Set	Stop-on contact excitation current low-speed multiplying factor
16	Pr. 276	Get/Set	PWM carrier frequency at stop-on contact
18	Pr. 278	Get/Set	Brake opening frequency
19	Pr. 279	Get/Set	Brake opening current
20	Pr. 280	Get/Set	Brake opening current detection time
21	Pr. 281	Get/Set	Brake operation time at start
22	Pr. 282	Get/Set	Brake operation frequency
23	Pr. 283	Get/Set	Brake operation time at stop
26	Pr. 286	Get/Set	Droop gain
27	Pr. 287	Get/Set	Droop filter time constant

Attribute ID	Parameters	Access	Name
38	Pr. 338	Get/Set	Communication operation command source
39	Pr. 339	Get/Set	Communication speed command source
40	Pr. 340	Get/Set	Communication startup mode selection
42	Pr. 342	Get/Set	Communication EEPROM write selection
45	Pr. 345	Get	DeviceNet address
46	Pr. 346	Get	DeviceNet baud rate
192	Pr. 500	Get/Set	Communication error execution waiting time
193	Pr. 501	Get/Set	Communication error occurrence count display
194	Pr. 502	Get/Set	Stop mode selection at communication error

Attribute ID	Parameters	Access	Name
202	C2 (Pr. 902)	Get/Set	Terminal 2 frequency setting bias frequency
203	C3 (Pr. 902)	Get/Set	Terminal 2 frequency setting bias
204	Pr. 125 (Pr. 903)	Get/Set	Terminal 2 frequency setting gain frequency
205	C4 (Pr. 903)	Get/Set	Terminal 2 frequency setting gain
206	C5 (Pr. 904)	Get/Set	Terminal 4 frequency setting bias frequency
207	C6 (Pr. 904)	Get/Set	Terminal 4 frequency setting bias
208	Pr. 126 (Pr. 905)	Get/Set	Terminal 4 frequency setting gain frequency
209	C7 (Pr. 905)	Get/Set	Terminal 4 frequency setting gain

REMARKS

- Values "8888" and "9999" displayed on the parameter unit indicate 65520 (0xFF0) and 65535 (0xFFFF) respectively.

(2) Service

Service Code	Description
0x0E	Get Attribute Single
0x10	Set Attribute Single

7.10 Class 0x70 to 0x79 (Extended Object III)

7.10.1 Class 0x70 to 0x79 Instance 1, 2

Set parameters of the inverter. Refer to the inverter manual for details of the parameters.

(1) Attribute

Class	Instance	Attribute	Parameters	Access	Description
0x70	1	10 to 109	<i>Pr. 0 to Pr. 99</i>	Get/Set	
0x71	1	10 to 109	<i>Pr. 100 to Pr. 199</i>	Get/Set	
0x72	1	10 to 109	<i>Pr. 200 to Pr. 299</i>	Get/Set	
0x73	1	10 to 109	<i>Pr. 300 to Pr. 399</i>	Get/Set	
0x74	1	10 to 109	<i>Pr. 400 to Pr. 499</i>	Get/Set	
0x75	1	10 to 109	<i>Pr. 500 to Pr. 599</i>	Get/Set	
0x76	1	10 to 109	<i>Pr. 600 to Pr. 699</i>	Get/Set	
0x77	1	10 to 109	<i>Pr. 700 to Pr. 799</i>	Get/Set	
0x78	1	10 to 109	<i>Pr. 800 to Pr. 899</i>	Get/Set	
0x79	1	10 to 109	<i>Pr. 900 to Pr. 999</i>	Get/Set	Parameter offset for calibration, gain
	2	10 to 49	<i>Pr. 900 to Pr. 939</i>	Get/Set	Analog value of calibration parameter

(2) Service

Service Code	Description
0x0E	Get Attribute Single
0x10	Set Attribute Single

7.11 Class 0x80 (Extended Object IV)

7.11.1 Class 0x80 Instance 1

Inverter monitored value can be read. Refer to the inverter manual for details of each monitor.

(1) Attribute

Attribute ID	Access	Description (Increments)
11	Get	Output frequency (0.01Hz)
12	Get	Output current (0.01A)
13	Get	Output voltage (0.1V)
15	Get	Frequency setting (0.01Hz)
17	Get	Motor torque (0.1%)
18	Get	Converter output voltage (0.1V)
19	Get	Regenerative brake duty (0.1%)
20	Get	Electronic thermal relay function load factor (0.1%)
21	Get	Output current peak value (0.01A)
22	Get	Converter output voltage peak value (0.1V)
24	Get	Output power (0.01kW)

Attribute ID	Access	Description (Increments)
25	Get	Input terminal status *1
26	Get	Output terminal status *2
30	Get	Cumulative energization time (1h)
33	Get	Actual operation time (1h)
34	Get	Motor load factor (0.1%)
35	Get	Cumulative power (1kWh)
62	Get	PID set point (0.1%)
63	Get	PID measured value (0.1%)
64	Get	PID deviation (0.1%)
71	Get	Motor thermal load factor (0.1%)
72	Get	Inverter thermal load factor (0.1%)

*1 Input terminal monitor details

b15														b0		
—	—	—	—	—	RES	—	MRS	—	RH	RM	RL	—	—	STR	STF	

*2 Output terminal monitor details

b15														b0		
—	—	—	—	—	—	—	—	—	—	—	ABC	FU	—	—	—	RUN

(2) Service

Service Code	Description
0x0E	Get Attribute Single

8 TROUBLESHOOTING

If a fault occurs and the inverter fails to operate properly, locate the cause of the fault and take proper corrective action by referring to the troubleshooting below. If the corresponding information is not found in the table, the inverter has problem, or the component parts are damaged, contact your sales representative.

Display		Possible Causes	Check Point	Corrective Action
Operation panel of inverter	LED of FR-A7ND			
E.OP1	Blinking Red	Connection time-out (Master did not send messages within time limit (4 × EPR).)	<ul style="list-style-type: none"> · Master sends messages within time limit. · Check for a break in the cable and a disconnected connector. 	<ul style="list-style-type: none"> · Shorten the send time interval of master. · Check for a cable and connector.
0.00	Off	No good contact between inverter and FR-A7ND	FR-A7ND is plugged firmly.	Plug in FR-A7ND. (Refer to page 6.)
		<ul style="list-style-type: none"> · Network power is off. · No other node is on the network. 	<ul style="list-style-type: none"> · Network power is on. · Other nodes are on the network. 	After checking required items at left box, power-on reset the inverter and restart the network.
0.00	Steady Red	<ul style="list-style-type: none"> · Duplicate node address · Network cable offline 	<ul style="list-style-type: none"> · No duplicate node address · Check that all cables are connected properly. 	After checking required items at left box, power-on reset the inverter and restart the network.

EDS file

EDS file can be downloaded from the web site.

Mitsubishi Electric FA Network Service MELFANS web
<http://www.MitsubishiElectric.co.jp/melfansweb>

Contact your sales representative for details.

REMARKS

- The EDS file has been constructed to ODVA standards on condition that a configuration software is used.
Consult your DeviceNet configuration software instruction manual for the proper installation of the EDS file.

Error Code List

Error Code	Name	Description
0x00	Success	Service was successfully performed by the object specified.
0x02	Resource unavailable	Resources needed for the object to perform the requested service were unavailable.
0x04	Path segment error	The path segment identifier or the segment syntax was not understood by the processing node.
0x05	Path destination unknown	The path referencing an object class and instance or structure element is not known or is not contained in the processing node.
0x07	Connection lost	The messaging connection was lost.
0x08	Service not supported	The requested service was not implemented or was not defined for this Object Class/Instance.
0x09	Invalid attribute value	The requested service has an error in attribute data.
0x0A	Attribute list error	An attribute in the Get_Attribute_List or Set_Attribute_List response has a non-zero status.
0x0B	Already in requested mode/ state	The object is already in the mode/state being requested by service.
0x0C	Object state conflict	The object cannot perform the requested service in its current mode/ state.
0x0D	Object already exist	The requested instance of object to be created already exists.
0x0E	Attribute not settable	A request to modify a non-modifiable attribute was received.
0x0F	Privilege violation	A permission /privilege check failed
0x10	Device state conflict	The device's current mode/state prohibits the execution of the requested service.

Error Code	Name	Description
0x11	Reply data too large	The data to be transmitted in the response buffer is larger than the allocated response buffer.
0x13	Not enough data	The service did not supply enough data to perform the specified.
0x14	Attribute not supported	The attribute specified in the request is not supported.
0x15	Too much data	The service supplied more data than was expected.
0x16	Object does not exist	The object specified does not exist in the device.
0x18	No stored attribute data	The attribute data of this object was not saved prior to the requested service.
0x19	Store operation failure	The attribute data of this object was not saved due to a failure during the attempt.
0x1C	Missing attribute list entry data	The service did not supply an attribute in a list of attributes that was needed by service to perform the requested behaviour.
0x1D	Invalid attribute value list	The service is returning the list of attributes supplied with status information for those attributes that was invalid.
0x1F	Vender specific error	A vender specific error has been encountered.
0x20	Invalid parameter	A parameter associated with the request was invalid.
0x27	Unexpected attribute in list	An attempt was made to set an attribute that is not able to be set at this time.
0x28	Invalid Member ID	The Member ID specified in the request does not exist in the specified Class/ Instance/Attribute.
0x29	Member not settable	A request to modify a non-modifiable attribute was received.
0x2A	Group 2 only server general failure	This error code may only be reported by group 2 only servers with 4K or less code space and only in place of Service not supported, Attribute not supported and Attribute not settable.

MEMO

REVISIONS

*The manual number is given on the bottom left of the back cover.

Print Date	*Manual Number	Revision
Dec., 2007	IB(NA)-0600342ENG-A	First edition
Dec., 2007	IB(NA)-0600342ENG-B	<div data-bbox="546 239 671 267" style="border: 1px solid black; padding: 2px;">Additions</div> Compatible with the FR-E740-11K, 15K